

Television in Daylight

6^d
MONTHLY

Television

The Official Organ of the Television Society

VOL 1. JULY 1928 No. 5



The first photo ever taken of the
New Baird Daylight Television Transmitter
in facing which the person whose image is to be
televised sits in ordinary daylight.

Read what Dr. J. A. FLEMING, F.R.S., says about it
on page 5.



THE WORLDS FIRST TELEVISION JOURNAL



PHILIPS NEON LAMPS FOR TELEVISION

We manufacture Neon and Projector Lamps suitable for television apparatus.

Obtained from all local electricians.

USE PHILIPS LAMPS—
AND SEE.

PHILIPS NEON LAMPS

PHILIPS LAMPS LTD., PHILIPS HOUSE,
145, CHARING CROSS ROAD, LONDON, W.C.2

Mention of "Television" when replying to advertisements will ensure prompt attention.

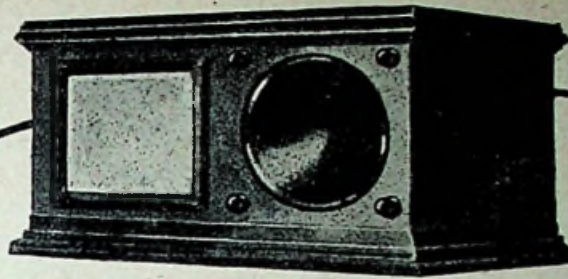

WIRELESS



ELECTRICITY

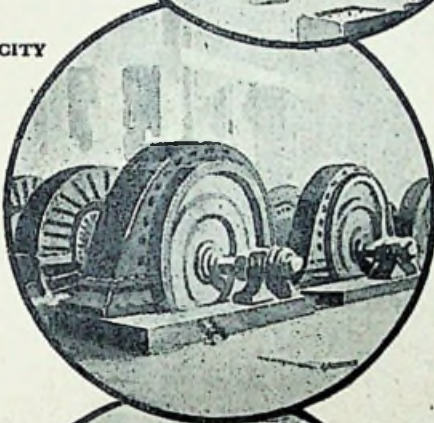

MECHANICS



CHEMISTRY



OPTICS



CINEMATOGRAPHY

JULY 1928

	PAGE
EDITORIAL	3
THAT BROADCAST PLAY	4
THE INVENTOR OF THE "FLEMING VALVE" VISITS THE NOW WORLD-FAMOUS BAIRD LABORATORY <i>By Dr. J. A. Fleming, F.R.S.</i>	5
WAVELENGTHS FOR TELEVISION	8
<i>By Lieut.-Colonel Chatwoode Crawley, M.I.E.E.</i>	
THE FAIRY ELECTRIC	10
POTASSIUM AND SODIUM	11
OPTICAL REFLECTORS	13
<i>By Professor Cheshire, C.B.E., A.R.C.S., F.I.P.</i>	
THE TELEVISION SOCIETY: LECTURE ON LIGHT- SENSITIVE CELLS	16
<i>By W. G. W. Mitchell, B.Sc., F.R.Met.S.</i>	
LIGHT-SENSITIVE CELLS	17
THE BAIRD TELEVISION SYSTEM IN AMERICA	20
BRIDGING SPACE	23
THE MARKING OUT AND CONSTRUCTION OF SPIRAL DISCS	25
NATURAL VISION AND TELEVISION	27
<i>By J. Darbyshire Montcath.</i>	
A NEW TELEVISION COMPANY	30
AN OFFICE BOY'S PART IN TELEVISION EXPERI- MENTS	37
INVENTION AND DEVELOPMENT	38
THE BEST LETTERS OF THE MONTH	39

Range...Volume Selectivity...Control

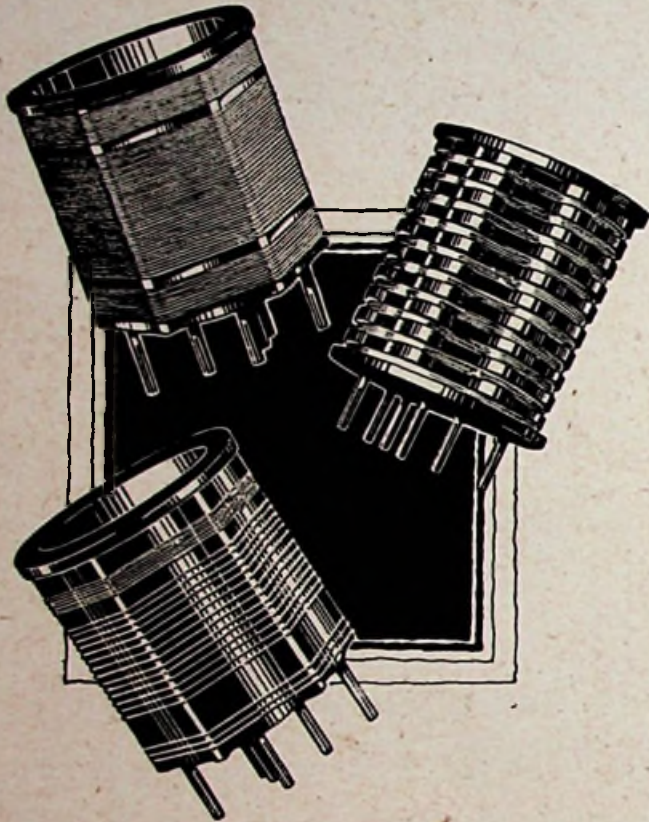

SELECTIVITY to the highest degree is easily obtained with Colvern Coils.

RANGE depends to an extremely high degree upon efficient coils, and it is very important that these should have a very low high - frequency resistance. To obtain this Colvern Coils are accurate space-wound. Experience proves that the use of Colvern Coils increases the range of a radio receiver. In the case of the Master Three Colvern Coils give maximum range on each of the three wavebands.

VOLUME is similarly dependent upon the efficiency of coils. Logically, the signal strength of distant stations is greatly increased by Colvern Accurate Space-Wound Coils.

Prices —

- Two Short Wave Coils: Space-wound—20 to 45 metres, and 45 to 90 metres. **7/6** Each.
- Broadcast Wave. Accurate Space-wound to give maximum efficiency. **7/6** Each.
- Long Wave. Sectional wound to give lowest high - frequency resistance. **8/6** Each.

COLVERN ACCURATE SPACE WOUND COILS

Colvern Ltd., Mawney's Road, Romford.

Mention of "Television" when replying to advertisements will ensure prompt attention.

Announcement

Readers are reminded that the construction of any television apparatus, as described in the issues of this Magazine, constitutes an infringement of the Baird patents and renders the infringer liable to legal proceedings unless he is the possessor of the constructor's sub-licence that may be obtained in accordance with the offer contained on page 37 of the April issue.

* * *

APPLICATION FORM.

In accordance with the offer contained on page 37 of the issue of "Television" for April, 1928,

PLEASE WRITE IN BLOCK CAPITALS.

I (Full Name)
of (Full Postal Address)
.....
..... hereby apply
(Occupation)

to Television Press, Limited, for the issue to me of a CONSTRUCTOR'S SUB-LICENCE and agree to be bound by the provisions of such sub-licence.

A STAMPED ADDRESSED ENVELOPE MUST BE ENCLOSED WITH THE ABOVE APPLICATION.

(J)

TELEVISION SOCIETY. MEMBERSHIP APPLICATION FORM.

July, 1928.

Please send me particulars and conditions of membership of the Television Society.

Name

Address

I desire to enrol as (Fellow or Associate) and submit qualifications:—

Academic Qualifications or
Scientific Pursuits

THE SECRETARY OF THE TELEVISION SOCIETY,
(Stamp enclosed.) 200, High Holborn, W.C.2.

ORDER FORM.

To TELEVISION PRESS, LTD.,
26, Charing Cross Road, London, W.C.2.

I enclose herewith {Postal Order / Money Order / Cheque} for 7/6 in respect of one year's subscription to "Television," commencing with the issue.

Name

Address

Postal and Money Orders should be crossed & Co. and Cheques should be made payable to Television Press, Ltd.

Television



THE WORLD'S FIRST TELEVISION JOURNAL

The Official Organ of The Television Society

Edited by A. DINSDALE, A.M.I.R.E.

Consultants: Dr. C. TIERNEY, D.Sc., F.R.M.S.; W. J. JARRARD, B.Sc. (1st Hons. Lond.), A.R.C.S., A.I.C.

Technical Editor: I. C. RENNIE, B.Sc. A.M.I.E.E.

Vol. I]

JULY 1928

[No. 5

EDITORIAL

IN this issue we are able to present to our readers a most remarkable article from the pen of our distinguished contributor, Dr. J. A. Fleming, who describes in a most fascinating manner his impressions of all the wonderful things he saw in the course of a recent tour round Mr. J. L. Baird's laboratories. After his article had been set up in type Dr. Fleming again visited Mr. Baird, on this occasion witnessing a most convincing demonstration of *daylight television*, Mr. Baird's latest development. Dr. Fleming has, therefore, added several extra paragraphs describing this latest wonder.

IN order fully to appreciate the significance of this achievement we have only to quote the oft-repeated question which is on everybody's lips: "When shall we be able to see the Derby or the Boat Race by television?" There is no doubt at all that this will eventually become possible, and this new advance of Mr. Baird's is one of the greatest steps in that direction ever made.

TO accomplish this miracle of witnessing outdoor events at a distance which may run into hundreds, or even thousands of miles it is at once apparent that the former method of illuminating the subject to be televised by artificial light will have to be abandoned, and ordinary daylight will have to be employed instead. It will thus be seen that Mr. Baird's latest achievement is

but a logical development in the required direction.

JUST how logical the development is may best be made clear to readers by giving a brief résumé of lighting methods which have been made use of to date.

MOST television experimenters, during the course of their early experiments, attempted first to transmit shadow-graphs by placing the object the shadow of which was to be transmitted in the beam of light from a powerful arc lamp, which beam was directed full on to the light-sensitive cell.

Mr. Baird's first television successes were obtained by flooding the object to be transmitted with intense light

obtained from a battery of powerful electric lamps. Light reflected back from the object then affected his light-sensitive device. Later, improvements in the sensitivity of his light-sensitive device enabled him to reduce considerably the intensity of the flood lighting.

A FURTHER improvement was made by using, instead of visible light, invisible infra-red rays, with the remarkable result that it became possible to see at a distance a person who was, apparently, sitting in total darkness.

ANOTHER of Mr. Baird's methods of illuminating the object, which avoids the discomfort of having to face a glare of light, causes a thin pencil of artificial light to travel rapidly to and fro across the face of the sitter.

AND now, by means of his latest transmitter, a photograph of which appears on our cover, the person whose image it is desired to transmit simply sits comfortably before the transmitter *in ordinary daylight*, just as if he were posing for his photograph.

THIS is truly a most outstanding advance, and undoubtedly marks the commencement of a new epoch of progress which will unquestionably make it possible, within a space of time which is likely to be reasonably short, for us to witness in our own homes, by television, such outdoor events of national importance as the Boat Race or the Derby.

Editorial & Publishing Offices:

The Television Press,
Limited,

26, Charing Cross Road,
London, W.C.2.

Telephone: Regent 6437.

SUBSCRIPTION RATES, 7/6 PER ANNUM,
POST FREE.

MSS. and other material for Editorial
consideration should be accompanied
by a stamped addressed envelope, and
should be typewritten.

Entire contents of this Journal copyright in the U.S.A., 1928, by Television Press, Ltd.

Foreign Translation Rights Reserved.

THAT BROADCAST PLAY

(As our artist imagines it)



The Studio scene as we imagine it and

as revealed to us by Television

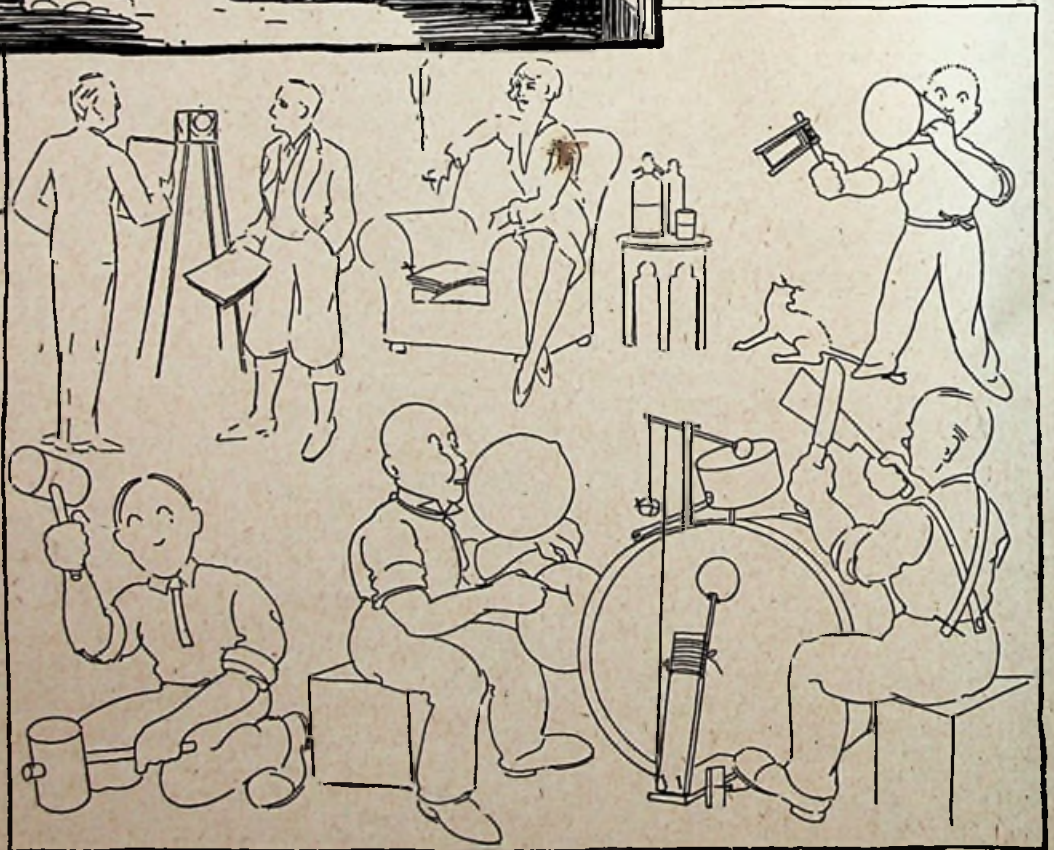

The Inventor of the "Fleming Valve" visits the now World-famous Baird Laboratory.

Dr. J. A. FLEMING, F.R.S., gives his Impressions of some of the wonderful things he saw—Television by Electric Light, Television in Darkness, and NOW—TELEVISION BY DAYLIGHT!

DAYLIGHT TELEVISION—A REMARKABLE ADVANCE.

Since the following paragraphs of this article were put in type the writer has had the opportunity of seeing in practical operation in Mr. Baird's laboratory a very striking advance in the apparatus for Television which has been recently made by Mr. Baird.

In this vast improvement it is not necessary for the face or object, the image of which is to be transmitted for Television, or "televised" (if one may venture to coin such a word), to be scanned by a brilliant beam of light traversing it, or to be flooded by powerful infra-red rays as explained below.

The object whose image is to be transmitted can be simply placed in diffused daylight, just as if an ordinary photograph of it had to be taken. The transmitting apparatus is then placed near to the object, and the image of it appears on the screen at a distance when proper synchronism is secured.

The advantage of this important advance will be clear. It means that the face of a singer or speaker can be transmitted by television at the same time that the voice is being picked up by a microphone for ordinary wireless broadcasting. It means a great step forward in the possibility of transmitting to a distance the image of moving objects or persons as seen in ordinary daylight, without exposing them to rapidly moving beams of light, or to dazzling illuminations or dark heat radiation.

The Television transmitter becomes, in fact, a more complicated kind of camera, in which the screen on which the image appears is not immediately behind the lens, but may be miles or hundreds of miles away.

J. A. F.

A VISIT to Mr. Baird's laboratory affords a very exceptional pleasure to anyone who is interested in seeing novel discoveries or inventions in process of development. Here is a new art in its nascent state, and no one can yet say what may not be its great utility when it reaches maturity.

It has been the writer's good fortune to be present, or to "assist" as the French say, at the birth or very early youth of electrical inventions which have been epoch-making in their ultimate effect.

In 1876, at Glasgow, he saw in the hands of Sir William Thomson, afterwards Lord Kelvin, one of the first speaking telephones which had crossed the Atlantic, and heard him say with what astonishment a few weeks before he had heard by Alexander Graham Bell's great invention intelligible speech transmitted over a telegraph wire for the first time.

Also, in January, 1880, the writer exhibited in action in a basement room of No. 11, Queen Victoria Street, London, a few of Edison's first carbon filament incandescent lamps,

WHAT Dr. FLEMING SAYS ABOUT BAIRD'S TELEVISION.

"Here is a new art in its nascent state . . ."

Television is "a quite genuine and veritable scientific invention . . . as important as telephony or broadcasting."

" . . . one can see at the receiving station the reproduced face moving from side to side, or smiling or opening the mouth or smoking a cigarette, exactly in correspondence with the actions of the sitter."

"This so-called 'noctovision' is a very wonderful and remarkable thing . . ."

" . . . the writer left the laboratory with the strong conviction that it was the birthplace of new, interesting, and very important inventions."

operated by current from 70 bichromate cells. Subsequently the writer was closely connected with the commercial development of these inventions.

The First Wireless Messages.

Again in April, 1898, he received from St. Catherine's, Isle of Wight, at Bournemouth, one of the earliest wireless messages sent 12 miles across the English Channel by Senatore Marconi's then new wireless telegraphy, and later on aided its evolution.

All these were germinal inventions which at their birth were sniffed at by official people or vested interests as being of no utility; but they laid the foundations of vast industries now employing hundreds of thousands of people, and without which human life now under its present conditions would be almost unthinkable.

At the present time, in addition to telephony, electric lighting and broadcasting, another art is coming into existence which will enable us to see at a distance or transmit visual impressions as well as sounds, speech

or music. This art is called television. In Mr. Baird's laboratory one can see it in operation, it is true, in an elementary form; but it is, nevertheless, a quite genuine and veritable scientific invention which may yet grow up into an industry as important as telephony or broadcasting.

The general principles of it have been fully explained in this journal already. Suffice it to say that in its earliest form, as may be seen in the National Science Museum at South Kensington, Mr. Baird's apparatus comprised a series of glass lenses placed in a disk in spiral arrangement which, when set revolving, formed a series of images of an illuminated object which were made to move rapidly within certain limits.

Behind this lens disk two other disks revolve, one of which has in it a large number of slots or little holes, and the other a spiral slit. The effect of these disks is to select very small areas taken in regular and quick succession from all parts of the image, and allow the beam of light from them to fall on a photo-electric cell, made as described by the writer in the May issue of TELEVISION.

How the Mechanism Operates.

The result is that a feeble electric current is emitted from the cell, which can be amplified by means of thermionic valves, and which is exactly proportional at any moment to the intensity of the slender beam

of light falling on the cell. This current can be transmitted by wire or by wireless to the receiving station, where it varies the glow of a neon lamp. At that place other slotted and rotating disks and rotating lenses then select the light from part of this glow and deposit it on a screen in such fashion that each patch of light occurs exactly in the same relative position on the picture screen as that which came from the part of the object giving rise to it. Hence there is an optical reproduction of the object. This image is seen depicted in various shades of red or reddish yellow and black, owing to the special kind of light given out by the neon lamp.

Synchronism.

Special means are adopted to synchronise the rotating disks at the two stations, that is to say, to make them run in step like two distant clocks which show exactly the same time and move at the same rate.

Supposing it is the face of a living person which is in this way transmitted, one can see at the receiving station the reproduced face moving from side to side or smiling or opening the mouth or smoking a cigarette, exactly in correspondence with the actions of the sitter. This is true television, and it is quite a different thing from the mere transmission of a photograph by wire or wireless.

But Mr. Baird has accomplished another more remarkable feat.

The flooding of the face of a sitter with the very brilliant light necessary for the above described method of

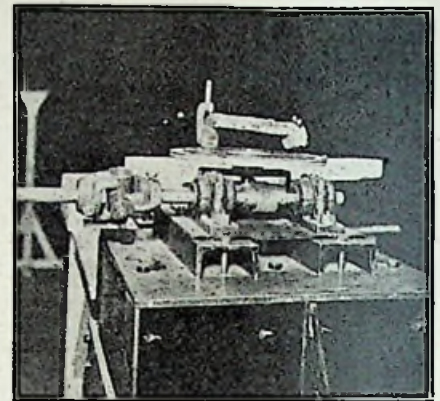

Another view of the Phonovision recording device.

achieving television is inconvenient, and would be painful to some persons.

In a previous article on radiation in this journal for June it has been explained that the radiation which affects our eyes as visible light is only a very small part of the total amount emitted by most sources of light.

Noctovision.

It is possible by means of screens of a certain material to cut off all the visible light from brilliant incandescent lamps and allow only the infra-red or dark invisible radiation beyond the red end of the spectrum to pass. The face of the sitter can be flooded with this dark radiation. He or she sits then in perfect darkness, as far as vision is concerned. Nevertheless the face or other object reflects this dark radiation, and by means of lenses an invisible image can be formed of it. This invisible image can be cut up or "scanned" into elements by the rotating disks in the same manner as a visible image, and the resulting impulses of invisible radiation can affect a certain kind of sensitive cell just as visible light affects a photo-electric cell, and cause this thermo-electric cell to generate or modulate an electric current.

This current is then transmitted to the neon lamp receiver, and we are able to witness the astonishing feat of reproducing on a screen the image of the face of a person sitting in an absolutely dark room at a distance, and see his face moving or smiling when no one in the room where the sitter is placed can see him at all.

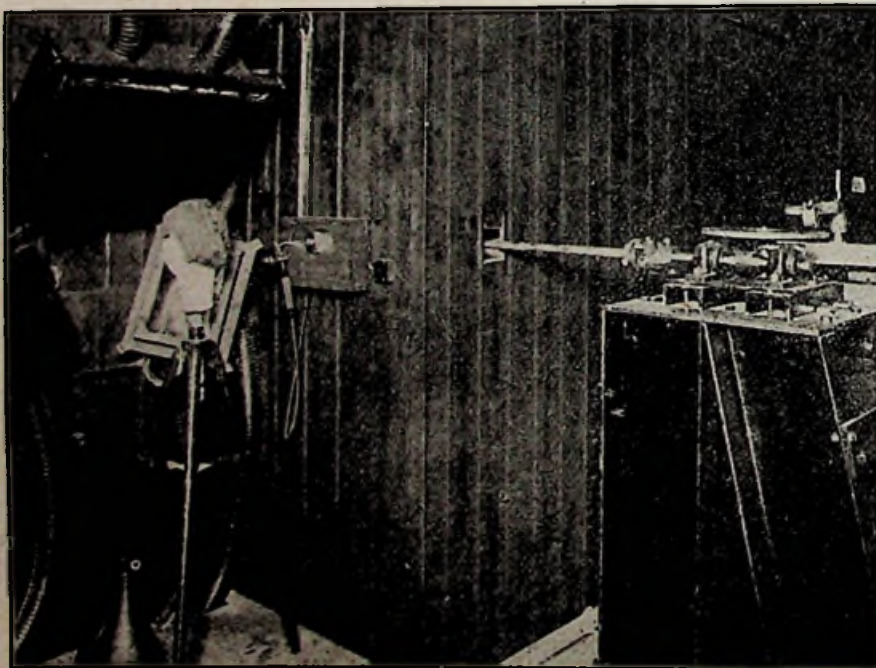

A corner of Mr. Baird's Laboratory. On the left is a Noctovision transmitter. On the right is the driving mechanism of a Phonovision recording device.

This so-called "noctovision" is a very wonderful and remarkable thing, and most surprising to anyone who

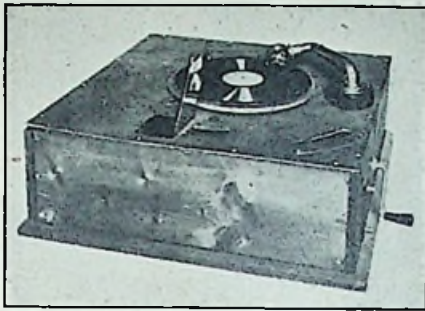

An experimental Phonovisor. Images appear in the slot in front of the record, and are made visible to the observer in the inclined mirror mounted beside the slot.

sees it for the first time. Mr. Baird gave his first public demonstration of this to members of the Royal Institution on December 31st, 1926.

The Light-Spot System.

Another type of his transmitter is that which employs a moving spot of light. The light from a powerful arc lamp is condensed into a slender beam not more than an eighth of an inch in diameter. By means of a revolving disk this spot of light is made to traverse the face of a sitter in such a fashion that it flies across again and again at slightly differing levels, so as to scan the face completely in less than one-tenth of a second.

In front of the sitter's face, but screened from direct light, are a number of photo-electric cells which gather light reflected from that part of the face which at any instant is illuminated by the spot of light. These cells generate a current proportional to the intensity of that reflected ray, and this is used at the receiver as above described to build up an image by the aid of a neon glow lamp.

Persistence of Vision.

It will be clear, then, that television essentially depends on the fact that an impression made on the retina of the human eye persists for a short time, viz., about one-tenth of a second. What we really see on the television screen is only a little spot or patch of light which flies across the screen repeatedly along slightly different paths, so as to cover the whole area in less than a tenth of a second. As it flies this spot of light is made more or less brilliant, so that it builds up an image of the

distant object, which is seen in its entirety by persistence of vision.

Another of Mr. Baird's ingenious inventions enables him to record the television image on a gramophone disk so that it can be repeated at any time with the aid of a proper television receiver.

Phonovision.

In making an ordinary electrically-cut gramophone record a soft wax disk is placed on a revolving table and a delicate little chisel cuts in it a spiral groove. The singer or speaker addresses a microphone as in broadcasting, but the electric current from this microphone is made to move the chisel to and fro and cut little indentations on the side of the groove which correspond in depth and number per inch to the intensity and pitch of the sound. Then from this soft disk an electrotyped copy is taken which is used to form the hard records we buy.

In his invention Mr. Baird uses the amplified current from the photo-electric cell to move the chisel cutting the master record. Hence the little indentations denote light intensities and not sound.

The hard record made from this soft disk can then be placed on a gramophone fitted with an electric "pick up," so that, when the disk revolves, it creates an electric current the variations of which are a copy of those that made the record. These "picked up" currents can be amplified and made to actuate a television receiver, and when certain arrangements are made to synchronise the disk it will reproduce the picture on the screen.

Speech and Vision on same Record.

Moreover, the disk can be made to carry a parallel spiral groove which contains a sound record to which will respond the ordinary needle and sound-box. Hence, a disk can be made which, when associated with a television receiver, will enable us to see the face of a singer with all its expression and to hear his or her voice at the same time. It remains to be seen whether the exact synchronism which will be required to secure the above result can be obtained by simple means.

The reader, however, will no doubt ask what probability there is of reproducing or visualising at a distance some public event or procession

such, for instance, as H.M. the King going in state to open Parliament, or the exciting finish of the Derby horse race. It may be well to explain in conclusion how this may possibly be done.

A telescope with a large objective lens forms a bright image of a distant object in its focal plane. The larger the lens the brighter this image. Suppose a camera could be made with a lens, say two feet diameter, of short focus. It would form at the focus a small but very brilliant image of external objects on a bright day.

A Suggestion.

Suppose at that place a revolving slotted spiral disk were placed. It could be arranged so as to scan the optical image and let through elements of it into a photo-electric cell. This would give rise to electric currents corresponding to the brightness of the image elements, and these might be used with a televisior receiver or employed to impress a soft gramophone disk from which hard records could be made.

In this way, with a proper local televisior receiver, it would be possible for people to "see" the moving procession or performance, and with an appropriate sound record even to hear the shouts and cheers of the crowd.

The writer is of opinion that this gramophone record of "televised" scenes may prove to be one of the most popular and perhaps the most remunerative of the results of Mr. Baird's inventions. Anyway the writer left the laboratory with the



What a Phonovision record looks like.

strong conviction that it was the birthplace of new, interesting, and very important inventions.

Wavelengths for Television

By Lt.-Col. CHETWODE CRAWLEY, M.I.E.E.

(Deputy Inspector of Wireless Telegraphy, G.P.O.)

TELEVISION must use short waves; indeed that seems to be the one point about television on which everyone is agreed. Not that disagreement about anything so new as television is unhealthy. On the contrary, the more bitter the disagreement the better for progress. Disagreement, in fact, is the finest spur to experimental research; but so far as one can see, from the very nature of television, there is no room for disagreement about the general statement that short waves are better than long ones.

Just what is meant by short waves in this connection is another question, and one which at present cannot receive a dogmatic reply. In fact, no reply at all is possible unless all the conditions are stated, and each set of conditions will bring forth a different reply; and even then with the present state of development of television each reply will be really hypothetical.

The situation is reminiscent of the early days of wireless, when a well-known expert, at an equally well-known parliamentary inquiry, in answer to what seemed a simple question, gave the excellent but not very illuminating reply, "Yes and No, and I should like to qualify both statements."

Mr. Baird used a wave of 45 metres for his television tests across the Atlantic because it was no doubt the best one available in all the circumstances at the time, and herein lies a matter of the greatest importance to the development of television. What waves are the most suitable, what waves are available now for experimental work, and what waves will be available when television enters the commercial field?

International Waves.

The chief work of the international radio telegraph conference which met at Washington last autumn was to draw up a list of waves for

international communication, and this allocation of waves will come into force throughout the world at the beginning of next year. In fact, all countries are already taking steps to come into line with the new allocation.

It is extraordinary, but nevertheless true, that no special waves have been reserved for television, so that as matters stand experimenters must

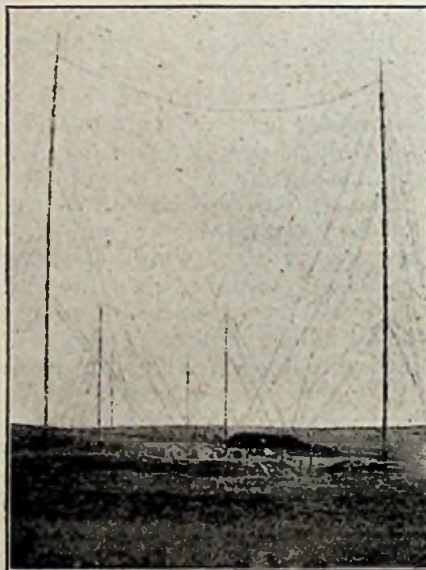

The Aerial System at the Stonehaven Wireless Station.

make use of waves which can also be used for other experimental purposes.

The waves allocated to amateur experimenters by this new convention are as follows: 175 to 150 metres shared with commercial services; 85 to 75 metres (shared with commercial services); 42.8 to 41 metres; 21.4 to 20.8 metres; 10.7 to 10 metres (shared with other experimental services); 5.35 to 5 metres (shared with other experimental services). 13.1 to 10.7 metres and waves below 5 metres are not reserved for any services. All other waves, with the exception of the above experimental

waves, are reserved for fixed, mobile, or broadcasting services, and when television is used commercially it will, presumably, make use of some of these waves according to the nature of the service on which it is employed, fixed, mobile, or broadcasting.

Waves for Television.

It seems to be the general opinion that the first commercial use of television will be in connection with the broadcasting services. The long wave broadcasting band of waves, 2000 to 1050 metres, which includes Daventry's wave, is on the high side for television, for reasons explained in an article in the April issue of TELEVISION; but the medium band, 545 to 200 metres, is a possibility. For long range work the waves under, say, 75 metres are the most suitable for television, and it is of interest to see how the position stands to-day in regard to these short waves.

For fixed services (that is, services between fixed stations) the number of waves available below 75 metres, under present conditions, is not more than 600, and more than half of these are already in use throughout the world. In considering such short waves it is necessary to include the whole world, as their range of action, even with small power, is world wide under favourable conditions.

The Importance of the Amateur.

This astounding result was first demonstrated by amateur experimenters in radiotelegraphy, a fact which must not be lost sight of by those who are sometimes apt to look for all important research in a strictly professional enclosure. Indeed this incident alone in the history of radiotelegraphy may well be held to justify, even from a narrow utilitarian point of view, the promotion of a Television Society and a special journal devoted exclusively to the new science.

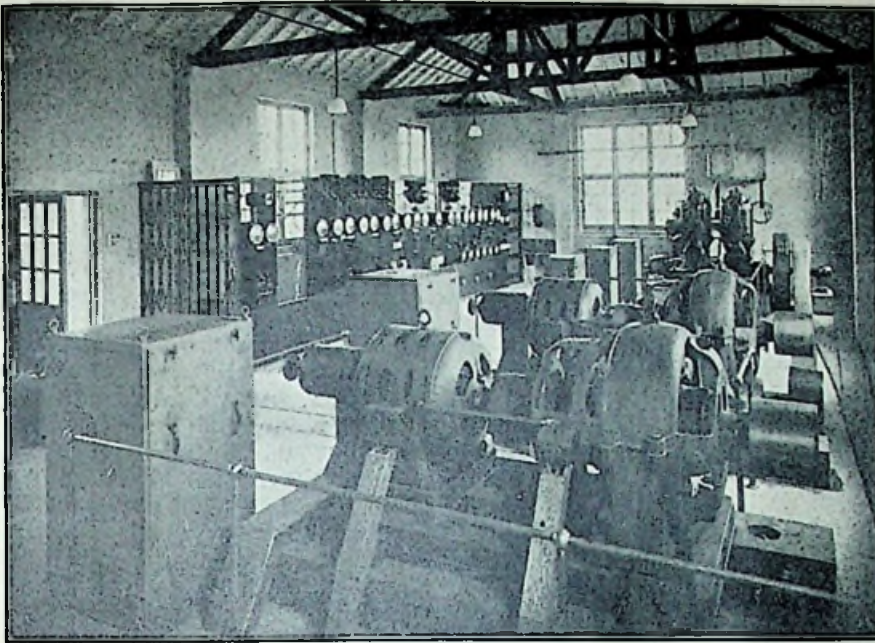

The Power Room at Northolt Wireless Station.

Now, these short waves have only just entered the commercial arena, and if over half are already in use the question arises as to what will be the state of affairs when television is sufficiently advanced to push its way in as well. It may be that by that time the technique of radiotelegraphy and telephony will have advanced so far that it will be possible to crowd waves much closer together than is the case at present without mutual interference, and fortunately this is almost certain to occur.

Indeed it is quite a fair assumption to make that before many years are past it will be possible to have 1200 waves in this band where now there is only room for 600. But it is just as fair to assume that radiotelegraphy and telephony will be quite ready to absorb these 1200 waves just as soon as they become available.

Radiotelephony and Facsimile Transmission.

We must remember that we are now only on the eve of opening up commercial radiotelephone services on short waves, and that when they do get going they will be more voracious of waves than radiotelegraphic services. The scope for long range radiotelephony is obviously enormous, because there is no cable competitor, and because people who speak the same language much prefer a telephone to a telegraph channel

for the bulk of their communications, a fact which is very apparent from the rapid advance of our inland telephone system at the expense of the telegraphs. No method has yet been devised for using the submarine cable for telephoning over long distances, so that in a large and scattered Empire like ours there is an almost illimitable scope for radiotelephony.

We are said, too, to be on the eve of opening up facsimile transmission

services on short waves over great distances, though this eve may prove as elongated as has that of the telephone services.

Here again there is obviously a wide field for commercial work, and this in time will absorb a great number of waves. It will be possible to transmit not only pictures but facsimiles of written and printed documents of all kinds at high speed. This will be a direct challenge to the present form of radiotelegraphy, and there are many who think that the story of the stranglehold of line telephony on telegraphy will be repeated when radiotelegraphy finds itself at grips with facsimile transmission.

Facsimile Transmission versus Telegraphy.

But this, after all, is immaterial, or nearly so, from the wave-length point of view, as the appetite of facsimile transmission for waves will be balanced to a great extent by the relinquishment of waves from the ordinary radiotelegraph services for the reason that both systems have the same aim, the transmission of documentary matter. But the appetite of radiotelephony for waves will be a far more serious business, as the aim is different. The transmission of speech may tend to reduce the transmission of documentary matter, but this will not be nearly so marked as in the case of short distance land

(Continued on page 19.)

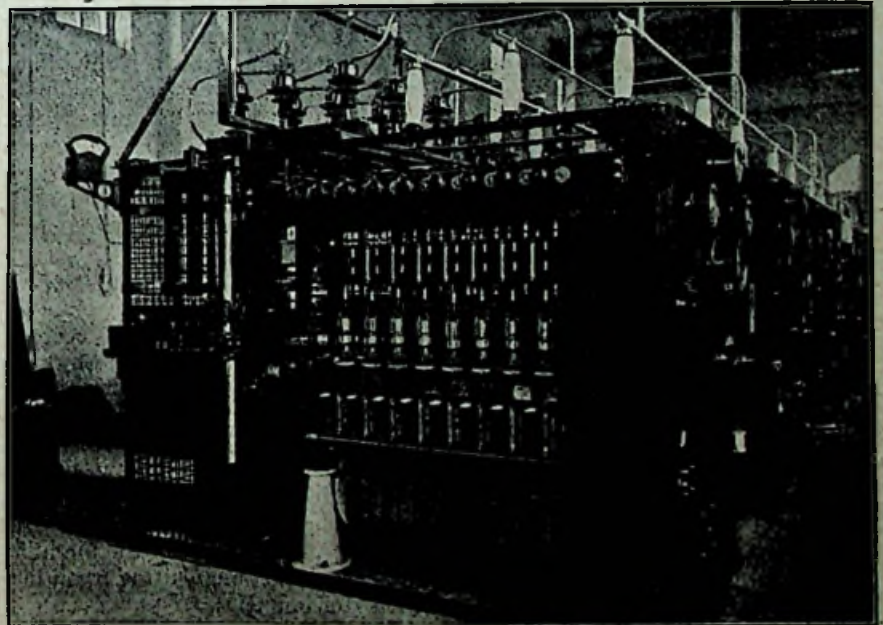

A Bank of High Power Valves (shown exposed) at Rugby

The FAIRY ELECTRIC

by
Charles Jones

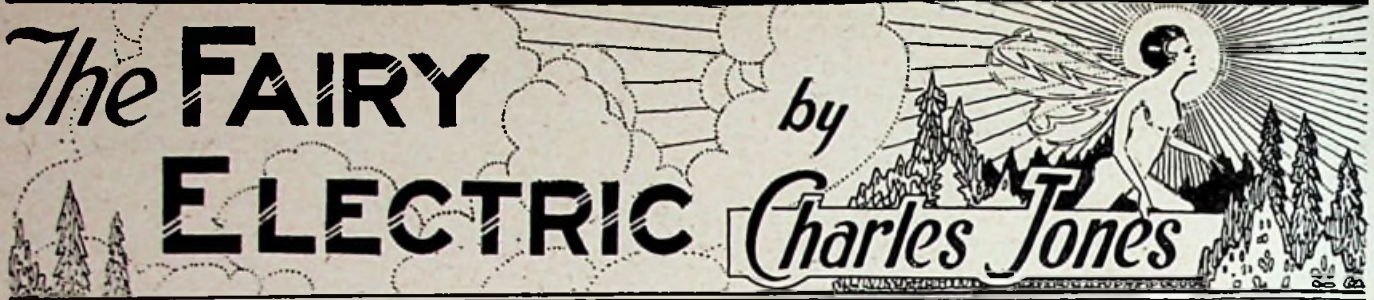

THE fairy Electric is the subtlest and most elfin agent in Man's employ. She has the elusiveness and unsubstantiated existence of a pixie, and, fairy-like in Her hundred invisible guises, She is solving the impossible complications of our childish adventures as well as any Tom-Thumb Godmother dight in dragon-fly gauze and flower petals ever did.

With moth-like touch She will set a needle trembling on a dial, but is a trackless fugitive if you pretend to see more than this flicker of a wing. Man can snare Her, as an ogre might, and keep Her under duress in some crazy castle (a dynamo must be a dungeon to such a light and airy spirit), but She will escape him if there be but a chink. Give Her the least chance and She will wing away and light a city, but She will struggle back to Her mother in the atomies of earthly caves at last.

Vital, potent little minx, She may be coaxed to work in gyves, will wrestle with a thousand pounding engines in Her sport, but in the end must hurry to the Unknown . . . for fairy sustenance, no doubt. Baffling little missioner, She will pick a song from the throat of the nightingale and perch it on a wire in a city street . . . a charity to the lonely, a ministry to the tired . . . and then, still clasping Her precious song, dwindle out to the awful orbit of Immensity.

"Where Does She Belong?"

Has anyone seen Her as She carries a song on Her rippling path in the air? No, She is too fleet and silent for a glimpse. Has anyone seen Her as She parachutes from Heaven to earth in a diamond train of lightning? No, that is but the sheen of Her vesture as She passes. Where does She belong? They hope to crack an atom and find Her there! She laughs! Oust Her from

that locked stronghold and She will still be in hiding on the farthest star. Why, the whole earth is but a ball fringed with a fluff of green which She can dangle on a frail magnetic thread!

"Man Holds Her in his Hand."

Capricious and delicate, majestic and mighty, you may mince the powder till it dissolves in Infinity and She is there; you may range the interstellar spaces to the last lonely mile, and there She is. Yet Man, who cannot find Her, holds Her in his hand. For his dust is as the dust of all the earth, and Her dwelling is in every speck. For all we know She is the nerve of the hand that guides Her, and has Her stateliest lodgment in the very soul of Man.

Of course, a scientist would not speak of Her thus. For the sake of self-respect he must treat Her as a captive "specimen," and in pursuit of his everlasting quest for new and temporary precisions he must describe Her habits and habitations, Her moods and miracles, in a very harsh language, which is ever enlarging and increasingly baffling. So that it is pleasant at times to fall back upon the old device of poetry which invests the mystical creatures beyond sight and finding with their just titles, and holds them in due awe and wonderment.

The fairy Electric! Though She swung a hammer at the forge of Creation, yet She has ever been as much a phantom as the wind, as gentle and as mighty, as viewless and as strong. Surely the scientist in his best moments, when the weight of learning is not too heavy on his brow, will give pause and see Her as a shy and simple angel, agile with primal energies, as from the birthday of measured Time, waiting upon him with Her bounties.

He may doubt if She should be christened with latinities at all.

And well he might, for what has She in hand now? Nothing less than a trick that any wild Dryad might play, and only the freakish tongue of myth could explain.

She waits at his elbow with a spilling bowl of Light in Her hands. She brings shadows, pearl, and grey, and half-grey, and sable, and will trace him pictures of all created things, and things devised, and happenings of the joyous and naughty world of men on a film of crystal. Not all in a moment. Mighty as She is in Her independence, She must be shackled for the uses of Man, and is a tricky Miss to cajole. But when She is reined in, and haltered with a rainbow, She will paint the obscure colours of the sea, and draw the beauty of many climes virile with life, and show the pageantry of things human and divine in the jewelled resplendence of colour.

And this She will do in Her own light-fingered way, cramming the Himalayas on to a glass measured in inches . . . showing the vast spectacle of the globe on Mercator's projection, as it were through the wrong end of a telescope! Mile by mile She will review the far horizons and reduce them to the vernier dimensions of art, with every tree intact.

"What an Atlas!"

Maybe She will bring Her singing birds and ballads and violins with Her; and set up a Theatre in your kitchen. All things are in Her brimming bowl of Light which She will pour, a torrent of living pictures, through a spyglass! So, the sick will travel unwearied, and the young go wandering to the heart's content with an empty wallet. Babies will laugh at Her, and old men stare.

No wonder the scientist woos Her, wayward as She is. For what a trophy She offers the priest of truth to lay at the feet of humbler men. Television!

Potassium and Sodium

Some Chemical Data

By JAMES SCOTT, F.R.S.A.

A GREAT deal is being heard just now about potassium and sodium—more especially the first-named—in connection with the production of photo-electric cells. These elemental metals, as specially utilised in such cells, are extremely sensitive to light stimuli, and are of great importance in the comparatively new science of television.

In TELEVISION for May, 1928, on page 11, Dr. Fleming, F.R.S., has something to say on the subject of both potassium and sodium, under the title of "Photo Electric Cells." For instance, one of his statements reads:—

"In this tube are placed fragments of clean potassium, the tube being kept full of inert gas or of hydrogen. By means of properly applied heat the potassium is melted, vaporised, and caused to distil over and condense on a cool part of the tube or on some metal plate inserted in it to receive the potassium."

Alkali Metals Best.

He also points out that metals of the alkali group are the best to employ in the preparation of photo-electric cells. Potassium and sodium are the two most widely known and commonest examples of these metals.

Both potassium and sodium are soft, silvery-hued metals. It is easy to mould them with the fingers at ordinary temperatures. They were both discovered by the famous scientific investigator and inventor Davy; but, owing to their remarkable properties, they have not entered very largely into commercial and industrial applications.

Because of their readily oxidisable traits, both elements have to be kept in naphtha, petroleum, or some other fluid which is entirely devoid of oxygen. Even so, it is impossible to prevent their surfaces from becoming encrusted with modified matter, quite different in texture from the lustrous

appearance of the internal portions. *This change would occur in leaky vacuum cells.*

A piece of either potassium or sodium, when removed from its protecting medium, wiped dry, and then cut open with a sharp knife—[steel blades cut it like putty]—shows on the newly-exposed surfaces a brightness, shimmer, and texture almost analogous to polished silver, except that a bluish bloom, very faint, may spread over it. But if the metal is held free for a time to allow the

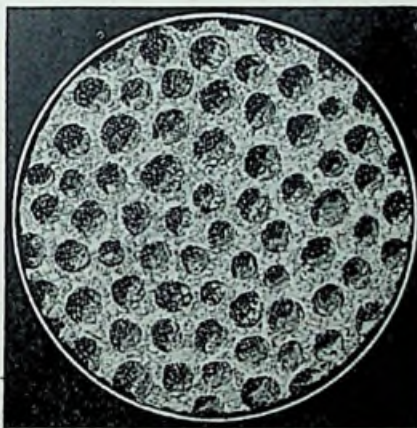

Fig. 1.
Greatly magnified view of effervescing surface of newly exposed silvery potassium metal. Thousands of minute bubbles are continually forming and bursting, modifying the element into oxide, and forming larger pores.

atmosphere to operate on it a dullness quickly spreads over the surface, and it gradually whitens, and becomes converted into a fine-particled, watery, crystalline powder.

It is really because of this rapidly oxidisable condition that either of these metals is found so valuable for purposes associated with the formation of photo-electric cells. But, naturally, extremes of such a character, as to induce the conversion of the element itself (even on small scales of action or reaction) into a compound of potassic or sodic constitution have to be avoided.

At present, both potassium and sodium are obtained by the electrolysis of solutions of their compounds. It is interesting to note that formerly, contemporaneously with the period of their discovery, potassium was prepared by fusing together, to a white heat, in an iron tube fitted with an exit channel, suitable proportions of potassium carbonate and finely divided carbon. The latter combined with available oxygen emanating from the carbonate, formed carbon-dioxide with it, and escaped as such. The isolated potassium was meantime vaporised, and was transferred as a green "gas" which condensed into naphtha in the form of a mass of metallic potassium.

The Instability of Potassium.

Some very strange chemical phenomena are involved in this process, apparently contradictory to accepted ideas of fundamental reactions; yet they are well understood in advanced circles of research. To deal further with such phases now, however, would be inappropriate to these pages, though it is advisable to refer to them in order to show how unstable potassium is in most ways, and unique in others.

Similar remarks can be applied to sodium. For the information of those who may require the knowledge, it must be pointed out that *all* potassium compounds (e.g., potash carbonate, potash nitrate, potash chlorate) contain the *metal* itself combined with something else; and that *all* sodium compounds (e.g., soda chloride, *table salt*, soda carbonate, *washing soda*, soda nitrate) also contain the metal itself. Potassium can be obtained from any of the first mentioned; sodium from any of the second lot.

The letter or symbol K signifies potassium, and stands for Kallum,

the Latin name for the substance. Na, an abbreviation of Natrium, is the technical expression for sodium. It originated in a similar manner. It is an interesting study to follow up the origins of scientific names.

If these items are borne in mind by the present reader they may en-

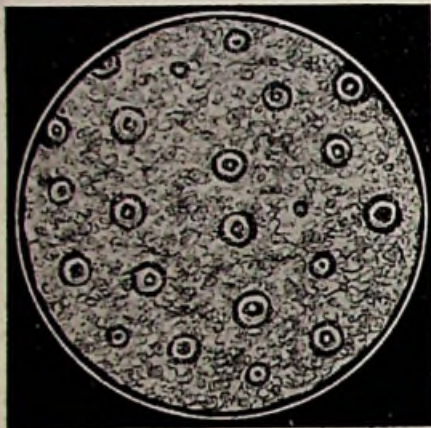

Fig. 2.

Enlarged view of the exposed surface of metallic potassium an hour or so after its exposure. Bursting bubbles are still resolving the metal into oxide and hydrate.

lighten him in his perusal of future references to the structure of photo-electric cells.

Both potassium and sodium have always proved serviceable as laboratory novelties, because of the fact that they *apparently* "set fire to water!" Whenever a piece of either metal, however small it may be—and large ones are dangerous to use in this way—is thrown into water a flame is instantaneously produced, and simultaneously a series of crackling sounds are emitted.

"Setting Fire to Water."

It is necessary to cast the sodium on to a scrap of blotting paper floating on the surface of the water, or otherwise keep it fairly still, or it will rush violently about as a dwindling silver bubble without any fire.

Now, the chemical truth of the matter is this: the strong affinity for oxygen possessed by both metals causes them to immediately combine with the oxygen of the water, thereby separating its hydrogen. The intensity of the performance is such that the hydrogen is ignited.

In both cases a caustic solution is evolved; that of potassium being potash hydrate; that of sodium,

soda hydrate. By boiling the solutions completely to the finality of evaporation the respective crystalline powders result.

These phases necessarily have a bearing on the use of the metals in photo-electric cells, because if leakages occur in the latter complications are bound to follow; and remember that however *minute* these reactions may be, and scattered apart, they will unavoidably affect the problems associated with the accomplishment of television.

Gas-filled Cells Best.

All these phenomena and possibilities are, of course, well known to the devisers and disposers of photo-electric cells; and for that reason, as well as for many others, the use of a vacuum associated with either potassium or sodium is avoided.

By the kindness of Mr. C. C. Paterson, director of the Research Laboratories of the General Electric Co., Ltd., Wembley (referred to at the top of page 12, TELEVISION, May, 1928, by Dr. Fleming), I have become acquainted with some distinctly cleverly made photo-electric cells intended for television purposes—in which potassium, properly sublimed, is effectively employed. I can say no more here, just now, than that the cells are filled with the inert gas argon, and that their use enables a very much higher percentage of efficiency to be obtained than is possible when vacuum cells are used.

I am concerned here mainly with the chemical aspects of the subject; and, after all, if it were not for the chemistry of matter there could not possibly be any occurrence of electrons. It should be more widely recognised that the two sciences (chemistry and electricity) are intimately blended, and that though at the dawn of creation electricity may have made matter, the latter has to be used at present (by man, at any rate) before he can secure the former.

"The Massing of Minutæ."

As with all other substances, whatever they may be, the success, failure, or variations between the two, depend on the massing of minutæ, so it must be in circumstances where either potassium or sodium is used in the construction or

photo-electric cells to ensure bombardments of primary electrons, secondary electrons, and so on; and surely electrons are small enough!

Hence, if they play upon uniform particles of matter they must produce better results for the purposes involved if minutely stable. The microscope should always be called into requisition in such experiments.

I expose a piece of freshly-cut potassium on a glass slide, and magnify it. It is found to be clear, with a brilliant silver sheen. Before many moments have passed, however, it has attracted oxygen to itself and become speckled as shown in Fig. 1 with a whitish film of potassium oxide.

Eventually larger, yet invisible, globules of moisture are drawn by the metal from the air—which is really always damp—and the oxide becomes partly hydroxide, or hydrate, and appears as shown in Fig. 2.

Microscopic Appearance of Potassium.

Before many hours have passed the surface, at first comprised of pure metallic potassium, has become transformed into a friable, moist, mixed



Fig. 3.

Magnified appearance of the exposed surface of metallic potassium several hours after exposure, showing networks of moisture, crystals of hydrate, and indefinite compounded potash—i.e., carbonate.

opaque and translucent, granular, semi-crystalline, and crystalline, substance, carbonic oxide (carbon dioxide) having also joined the company, and the appearance of the potassium accords with that shown in Fig. 3.

Sodium behaves in a similar way.

Optical Reflectors

By Professor CHESHIRE, C.B.E., A.R.C.S., F.I.P.

[This is the first of a new series of articles by Professor Cheshire on optical subjects likely to be of special interest to those of our readers interested in the working of known types of television apparatus, and the designing of new ones. These articles will also deal with the construction and applications of optical elements made available by optical science in recent years.—EDITOR.]

IT is curious to reflect that the belles of the Stone Age who, some half a million years ago, knelt down by the sides of still pools to gaze upon the reflection of their charms, and apply the few cosmetics then known, were using an optical arrangement which, judged by the perfection of the optical images produced, has never been surpassed by optical science. The image produced by a flat reflecting surface of such an order of accuracy as that to be found on still water is appreciably superior in several important respects to the best image that can be produced by any lens, or combination of lenses. It is, however, a virtual image. The reflected rays do not actually come from it, they only appear to do so. A plane mirror, therefore, cannot do the work of a photographic lens.

The modern optician depends to a great extent upon reflecting elements, either plane or curved, in the designing of optical apparatus. The telescopes, periscopes, range-finders, gun-sights, position-finders, surveying instruments, signalling apparatus, and a large number of other instruments, used in such great numbers during the late war, all embodied in their construction, to a greater or less extent, the plane-reflecting element.

Fundamental Experiments with Plane Reflectors

A number of instructive and fundamental experiments can be carried out with three squares of ordinary looking-glass. (The thinner the glass the less troublesome becomes the light reflected from the first surface.) For use with these the letter "P" should be drawn boldly on a piece of cardboard, such as a visiting card.

Experiment 1.—Take one of the mirrors and hold the card in front of

it as shown by Fig. 1. Observe the reflected image. The letter "P" is reflected as "q," i.e., it appears laterally reversed, or right for left, so that a right-hand glove, thrown down in front of the mirror, appears as a left-hand glove. Move the card in its own plane to the right and left, and up and down. The image moves

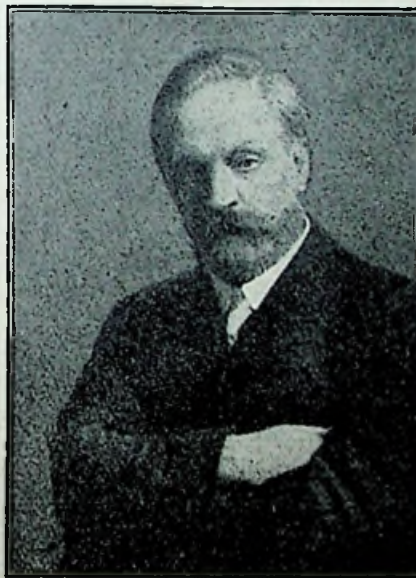

Professor CHESHIRE, C.B.E., A.R.C.S., F.I.P., the author of the accompanying article, was formerly Director of the Optical Engineering Department of the Imperial College of Science and Technology, South Kensington. He is one of the greatest authorities on optics in this country.

with the object in every case. It is always seen as being opposite to the object. Each point of the object is duplicated in the image—the plane of the mirror is a plane of symmetry for object and image.

Experiment 2.—Take two of the square mirrors and erect them on the table, edge to edge, so as to make a right-angle with one another, like the covers of a half-open book, as

shown by Fig. 2. The letter "P" is now reflected as "P": there is no reversion as in the last experiment. On moving the card vertically the image follows it as it did in Fig. 1, but when the card is moved sideways the image moves off in the *opposite* direction.

Experiment 3.—Arrange two of the mirrors as in Fig. 2, but on the face of the third mirror instead of the table top. The three mirrors will now (Figs. 3 and 4) be mutually at right angles to one another, as though lining one of the inner corners of a box, and forming what is sometimes called a triple reflector. The letter "P" is reflected (Fig. 3) as "q," and in whatever direction the card is moved across the axis* of the mirror, the image moves off in the opposite direction.

A Weird Effect.

A weird effect is obtained by looking directly into the mirror. Nothing is seen distinctly except an eye stolidly staring in the corner where the mirrors meet (see Fig. 4), and this eye appears to remain fixed in space no matter how the observer moves about in the room in which the experiment is carried on. Closing either the right or the left eye produces no effect. The observer becomes more and more bewildered until he is tempted to ejaculate: "Good heavens! Whose eye is it, and which?"

This triple reflector, if angle-true, possesses the remarkable property of returning upon itself a beam of parallel light entering it at any angle, within wide limits, of inclination to

* The axis of a triple reflector is the axis of symmetry, i.e., a line passing through the common meeting point of the three mirrors, to each of which it is inclined at the same angle.

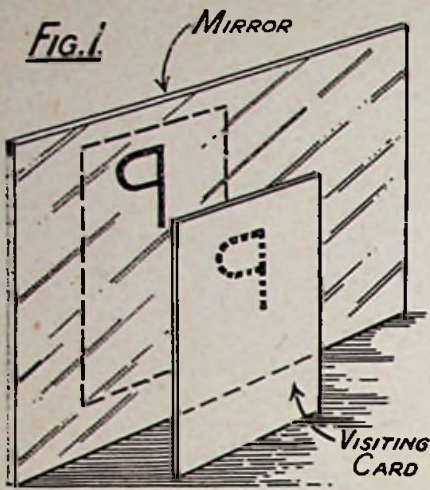

The effect of a single reflecting surface.

the axis of the reflector, so that, in the experiment with the eye, the right eye sees the reflection of itself only—the reflection of the left eye is invisible to it. Similarly with the left eye.

This property of the triple reflector has been taken advantage of in several ways. Such a reflector, for example, could be fixed to the bottom of an aeroplane to reflect back along itself a beam from a searchlight below. Then by means of a postcard, flicked backwards and forwards across the opening of the reflector, an airman could transmit messages by Morse which could not be seen at any place other than in the immediate vicinity of the searchlight.

Optical Action of Plane Reflectors.

The optical action of the most complicated system of plane reflectors can

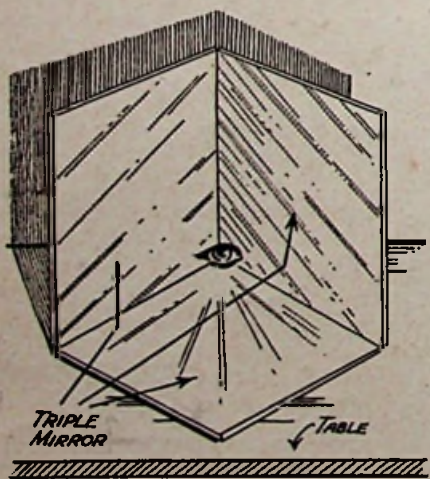

FIG. 4

The weird result of staring at a triple reflector. Only one stolid eye is seen.

be determined from a single law, which may be stated thus:

When a ray of light is reflected at a point of a plane surface the reflected ray and the incident ray make equal angles with the normal to the surface at that point, and the incident ray, the normal and the reflected ray lie in the same plane.

This law can be proved experimentally, and it can also be shown to follow simply from Huygen's wave-theory of light referred to on p. 35 of the April issue of TELEVISION. This proof follows these lines:— Suppose that light waves starting from the point O, Fig 5, strike the surface of the plane mirror A. Each

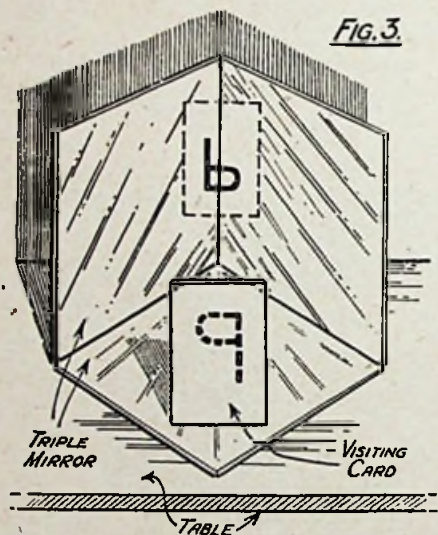

FIG. 3

Three mirrors arranged to form a triple reflector.

spherical wave will first strike the reflecting surface at a point which occurs at the foot of a perpendicular dropped from the point O, on to the surface of the reflector A, so that the reflected wave must, from considerations of symmetry alone, have for its centre a point I, which occurs in the perpendicular dropped from O, and at a distance from the mirror equal to that of the point O. The point I is thus said to be the image of the point O in the mirror A—a phrase of which we shall make considerable use.

A direct wave and its corresponding reflected wave are shown as simultaneously passing through the point B. OB is a ray for the first of these waves, and BC, a continuation of the radius IB, a ray for the second one. The line BD is a normal to the mirror A at B, and is therefore parallel to OI.

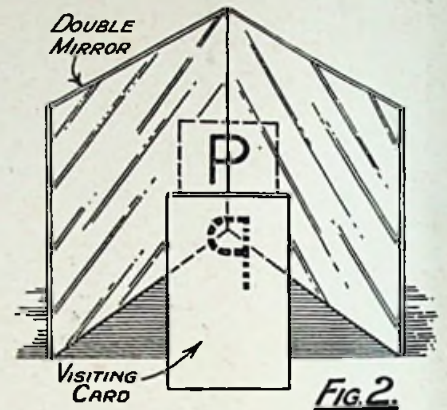

FIG. 2

Two mirrors arranged at right angles, to form a double reflector.

Since, then, the angle α at O and the angle β at I are equal, and these angles are respectively equal to the angles of incidence and reflection, the angle of reflection is equal to the angle of incidence and the ray OB, the normal BD, and the ray BC lie in the same plane, i.e., the plane of the paper in the figure.

It should be noted that it follows from Huygen's construction, here briefly referred to, that (1) spherical waves are reflected accurately as spherical waves, and (2) that the position of the image point is independent of the wave-length of the light employed. For white light, therefore, it is the same for all colours. Strictly speaking, neither of these two statements is true for an image produced by a lens, as we shall see later.

In some cases it will be found that a perpendicular cannot be dropped to the surface of the mirror. This surface must in this event be produced as shown in dotted lines in Fig. 6 as a

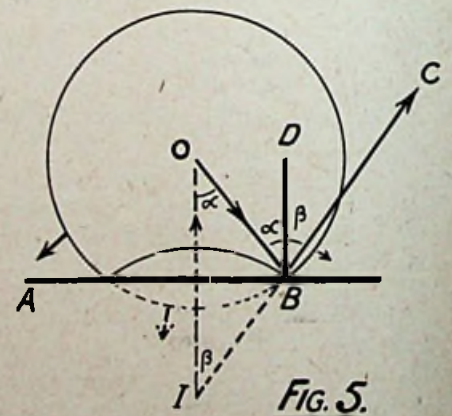

FIG. 5

The reflection of light waves and rays by a plane mirror.

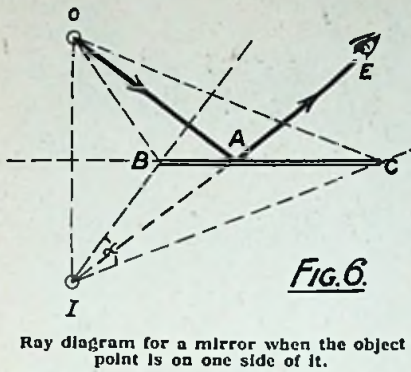

FIG. 6.

Ray diagram for a mirror when the object point is on one side of it.

preliminary to finding the position of the image. To trace a ray from the object O to the eye at E it is only necessary to draw a line in the direction EI until it intersects the mirror at A, and then connect A and O. The ray required takes the path OAE.

Fig. 7 illustrates multiple reflection such as occurs in the kaleidoscope. Two mirrors A and B are reared perpendicularly to the plane of the paper, and at right angles to one another. An object, such as a candle, is placed at O, and an eye, E, as shown. It is required to trace a ray from O to E which is reflected twice, once by each of the two mirrors. We must first find the positions of the various images by the usual device of dropping perpendiculars from O on to A and B, and continuing them for equal distances on the other side.

These images I_A and I_B must fall upon a circle struck from C with a radius CO. Any ray which enters the eye after a single reflection from A must do so from I_A , and similarly, in the case of the mirror B, from I_B .

Now let us find the position of the image of I_A in B and I_B in A. The two will coincide in I_{AB} . Any ray, therefore, which enters the eye after two reflections must do so in the direction E, I_{AB} . Draw this line and from its point of intersection with B continue it towards I_A , and from the point of intersection of this line with A to O, and the problem is solved.

If the eye had been above the line $I_{AB}C$ continued the first reflection of the ray from O would have taken place on the mirror B.

Optical "Billiard-Table" Problem.

Fig. 8 illustrates in plan an old and interesting optical problem known as the billiard-table problem, which we will consider because it affords a

beautiful example of how a ray can be traced through a system of plane mirrors.

Plane mirrors 1, 2, 3, and 4 are arranged to stand vertically on the top of a table in the form of a rectangle, the reflecting surfaces being turned inwards. A candle or other object is placed at A, and the eye of an observer at B. It is required to find out whether it is possible for the eye at B to see the candle at A by means of light which has been reflected in succession by the mirrors 1, 2, 3, and 4; and to trace a ray from A to B satisfying this condition.

From what we have already seen, if light emitted by the candle A is reflected by the mirror 1 then, after reflection, the light rays must appear to radiate from the image I_1 of the candle in the mirror 1. For the sake

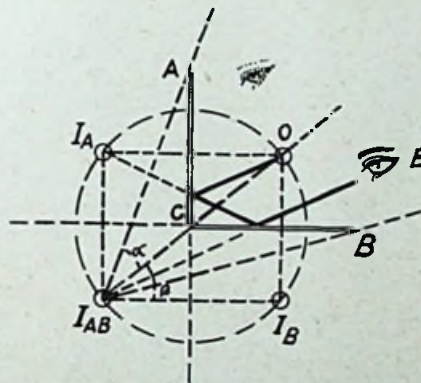

FIG. 7.

Imaging by two reflectors placed at right angles to one another.

of simplicity we will consider the candle as replaced by a point so that we may say that the point I_1 is the image of the object point A in the mirror 1.

Further, we know that all light rays emanating from the point A, which have been reflected in succession from the mirrors 1 and 2, must then radiate from the point $I_{1,2}$ which is the image of the image point I_1 in the mirror 2. By similar reasoning we find the image $I_{1,2,3}$ for successive reflections from the mirrors 1, 2, and 3, and finally the image $I_{1,2,3,4}$ for successive reflections from the four mirrors.

We must be careful at this stage. All that our construction tells us, up to the present, is that if light does reach the eye at B from the candle A,

after being reflected by the mirrors in the order named, then that light must appear to radiate from the point $I_{1,2,3,4}$.

To solve the problem completely we must trace a ray between A and B, and since our image points belong to the source A, and not to the eye B this ray must be traced backwards from B to A, in the following way:—

From B draw a line towards the image $I_{1,2,3,4}$ to intersect the mirror 4, and from this point of intersection draw a line towards the point $I_{1,2,3}$ to intersect the mirror 3.

Similarly, draw lines to the image points $I_{1,2}$ and I_1 , and from the last point of intersection on the mirror 1 draw a line to the object-point A itself. The line thus drawn from B to A shows the path of a ray passing from A to B, and since this ray is reflected from the mirrors in the order required our problem is solved.

For some positions of the candle on the table it will be found that the ray traced backwards from B does not intersect the mirrors in the order required, and does not after four reflections pass through A. Our problem then is impossible. In a complete solution the angular aperture of the system must be taken into account, a subject which will be dealt with later.

The Production of Optical Plane Surfaces.

An "optical flat" is a sheet of glass, or it may be quartz, one surface of which has been carefully worked to as perfect a plane surface as possible, and is used by the optician for the same purpose that the "surface plate" is used by the engineer, i.e., to test and produce other flat surfaces. Optical flats are tested by what is known as the Newton-ring or colour method.

When a soap bubble is placed in sunlight, as everyone knows, it is

(Continued on page 19).

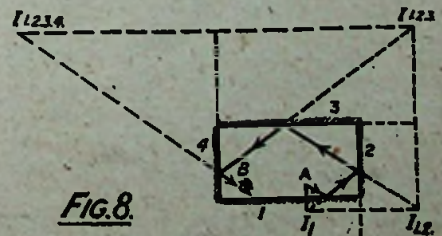

FIG. 8.

Diagram showing the path of a ray reflected in one plane by four mirrors arranged like the cushions of a billiard table.



The Television Society

Lecture on Light-Sensitive Cells

By

W. G. W. MITCHELL, B.Sc., F.R.Met.S.

A MEETING of the London Section of the Television Society was held on June 5th at the Engineers' Club, Coventry Street, to hear Mr. W. G. W. Mitchell, B.Sc., F.R.Met.Soc., one of the founder members of the Society, lecture on "Light-Sensitive Cells."

Dr. C. Tierney, D.Sc., chairman, calling on Mr. Mitchell to give his lecture, said he was sure the lecture was one to which they were all looking forward, because in view of the fact that television was as yet in the experimental stage—something beyond its infancy—they had come to the conclusion that the heart of the television set was the light-sensitive cell, and the more they knew about the cell the better it was for those who were engaged in experimental work.

It did not follow, of course, that the lecture would be anything like the last word in our knowledge of light-sensitive cells, but they would hear something of the cell which would assist them very much in its practical application to their work.

He looked forward very much to hearing from Mr. Mitchell about his work in investigating light-sensitive cells and light-sensitive substances.

Mr. W. G. W. Mitchell.

Mr. MITCHELL:—Speaking quite broadly, there are three main problems in television as we understand the art to-day. They are these: (a) That of converting light signals into electrical energy. (b) That of transmitting these electrical impulses to a distance. (c) That of converting the electrical signals back again into light signals.

Given means for accomplishing these three essentials, which as I have already said, constitute the three main problems of television,

it becomes a matter of developing each to a high level of speed, accuracy, and sensitivity. This Society, ladies and gentlemen, of which you and I are members, is very intimately concerned with these developments. Our object is to study these very problems, and as the result of study and experiment to contribute something to the common stock of knowledge, for it is surely realised by everyone present to-night that without research, and consequently without progress, no society such as ours can hope to continue to exist as a progressive body.

Just how far these problems have

been successfully overcome, or to what degree, it is not for me to attempt to say. Members who were present at the lecture-demonstration given by Mr. J. L. Baird last month must judge for themselves. I would like, however, to say one thing in this connection. No one, I think, except those directly in touch with Mr. Baird, really knows the tremendous amount of work and enthusiasm that he puts into these problems and which he successfully enthralls into his followers. So that, having given the members of this Society a lead, the lead for which I asked in my opening remarks at the first formal meeting of the members, I feel we must all put our shoulders to the wheel.

Accidental Discovery of Properties of Selenium.

To-night I propose to take up a little of your time in a consideration and discussion about light-sensitive cells, a subject about which very little or nothing was known until the almost accidental discovery of the metal selenium some 50 years ago. But it is only quite recently (within the last ten years) that another and more useful light-sensitive device, the photo-electric cell, has been to any extent developed.

Perhaps during the course of my remarks to-night I shall be able to bring to your notice some special lines which require further investigation, and if you have any time and the necessary inclination during the long summer vacation when we have decided not to hold meetings of the Society, then this lecture will have served its purpose.

As the lecture proceeds we hope to successfully demonstrate one or two principles. But I would like to say now, with regard to the demon-

(Continued on page 31).



(Photo by courtesy of G.E.C., U.S.A.)
A typical form of Photo-Electric Cell.

LIGHT-SENSITIVE CELLS

The Liquid Type—Part II

By H. WOLFSON

WE must now consider the apparatus and the methods employed to detect and measure these minute photo-electric currents, generated as we have seen in solutions of certain dyes such as Rhodamine B, Resorufin, etc. Naturally we cannot expect to measure them on the ordinary type of voltmeter, since the magnitude of the current is of the order of a few millivolts only.

Staechelín makes use of the Poggendorff compensation method, which method I have myself employed with considerable success. This is, in fact, the ordinary potentiometer method for comparison of E.M.F. The apparatus consists of a two- or four-metre potentiometer wire, with a sliding contact and scale, graduated in millimeters (AB, Fig. 1), across whose ends is applied a constant potential, obtained from a two-volt accumulator.

Measuring Potential Drop.

We then have, if the wire is uniform, a constant fall of potential along the wire. That means that if we tap off half-way along the wire the potential difference across the portion tapped off (AX, Fig. 1) is half that across the ends of the wire, i.e., one volt. Thus we see that the voltage across AX for any position of X is equal to $\frac{AX \times 2 \text{ volts}}{XB}$

In the circuit AX is included the E.M.F. to be measured, in this case the photo-electric cell, and a sensitive galvanometer G, which may be either a sensitive mirror galvanometer or a capillary electrometer. I use the latter type of instrument, a description of which appears a little later on.

It is possible then to find a point X on the potentiometer where the galvo gives no deflection, the so-called null point. Since the batteries were connected in opposition we see that

the E.M.F. of the photo-electric cell is the same as the potential across AX. If then we illuminate the cell,

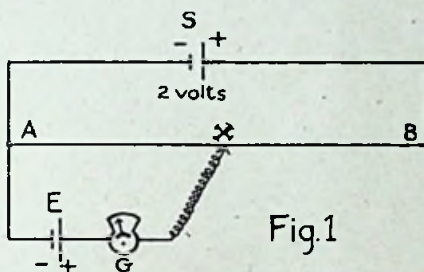

A.B. Potentiometer Wire. S. Sliding Contact. G. Galvanometer. E. E.M.F. to be measured. S. Accumulator.

and thereby give rise to a photo-electric current, we shall disturb the balance and there will be a deflection of the galvo. After re-adjusting the potentiometer to restore the balance, if we observe the distance which we move the slider we can calculate the E.M.F. produced as a result of illuminating the cell. The accuracy is very high, since we can read the potentiometer to an accuracy of one millimetre, which corresponds to a voltage drop of $\frac{2}{2,000}$ ths of a volt or $\frac{2}{4,000}$ ths of a volt, according to whether the length of the potentiometer wire is 2,000 or 4,000 millimetres. That is to say, we can take readings to within one-millionth or half a millionth, as the case may be.

The other part of the apparatus, shown diagrammatically in Fig. 2, consists of a U tube in which is placed the solution under examination. This is fitted with a glass tube in one limb of such a diameter as to leave room for the electrode of platinum foil (P), connected by a salt bridge of normal potassium chloride through a beaker of the same solution with a normal calomel electrode (C), which can either be made at home or bought for a few shillings at any scientific suppliers. Fig. 3 shows the complete disposition of the apparatus.

Capillary Electrometer.

This instrument, although known in many forms, can be constructed by the experimenter in a very simple manner. Fig. 4 gives two simple forms of the instrument.

In Fig. 4 (a) the outer vessel is a test tube (T) three inches high and one inch in diameter, which is filled with accumulator acid and carries a cork fitted with a tube which consists

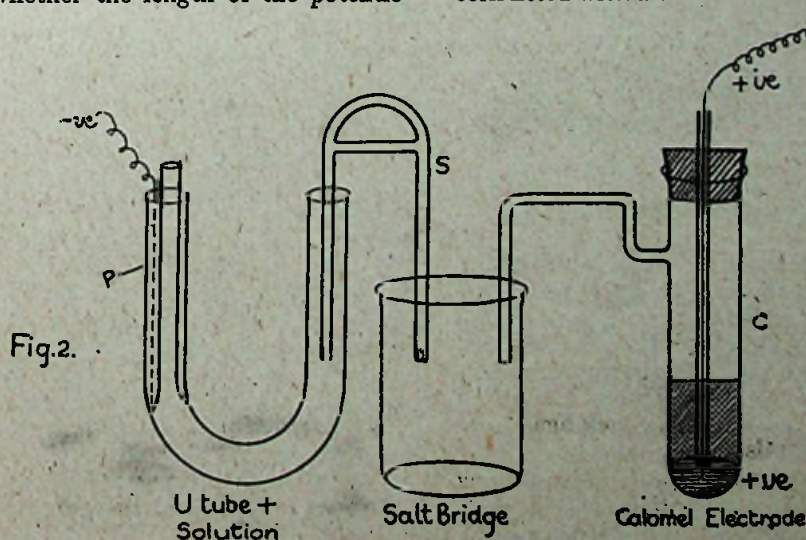

of a piece of 5 mm. tube fused on to a piece of 1 mm. capillary tubing. This tube is nearly filled with pure dry mercury, as illustrated (M).

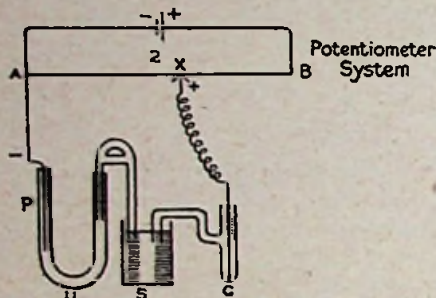

Fig. 3.

P. Platinum Foil. U. U-Tube. S. Salt Bridge. C. Calomel Electrode.

The outer tube (Fig. 4 (a)) has a platinum wire (P) sealed in at the bottom, as shown, and a small globule of mercury is placed over this to ensure a good contact. The other connection to the circuit is taken from the mercury in the U tube. If the instrument is arranged so that the acid contact is always positive no trouble will be experienced. Care must be taken to see that the capillary is filled with acid above the mercury thread C, but no acid should be allowed in any other part of the U tube.

This is accomplished by blowing down A to expel a few drops of mercury, which drop to the bottom of the tube and form the contact, and on ceasing to blow the acid is sucked back automatically.

The other form is slightly better, since with a horizontal capillary one obtains a larger deflection. The diagram (Fig. 4 (b)) is self-explanatory. Both these instruments need a low-power microscope to read them accurately, but one such as opticians sell for a few shillings should be sufficient. Personally I use a ¼-inch objective for the purpose.

Alternative Construction.

The calomel electrode is shown in two forms in Fig. 5 (a) and (b). The more scientific form needs a little glass-blowing (cost is. 6d.). Either form has a layer of mercury (M) at the bottom, and over this is placed a layer of paste (P) made by shaking mercury with calomel and a solution of potassium chloride containing 74.5 grams per 1,000 cubic centimetres of water. Over this is poured

the potassium chloride solution (S) which is saturated with calomel. A tight rubber stopper carrying a glass tube with a platinum contact completes the cell. The tube C and the beaker and salt bridge are also filled with the same potassium chloride solution.

To carry out the experiment, first balance the circuit with the cell in the dark. Then illuminate the cell, and if the solution is photo-sensitive there will be a change in the balance point.

It might appear at first sight as if I had gone too much into detail over the detection and measurement of photo-electric currents, but when we realise that the most important part of any television transmitter is the "Electric Eye," and that the only part of the Baird televisior which is being kept a strict secret is the light-sensitive device which Mr. Baird has

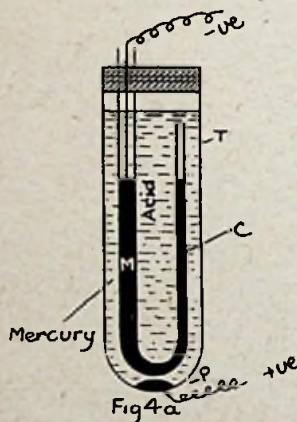

Fig 4a

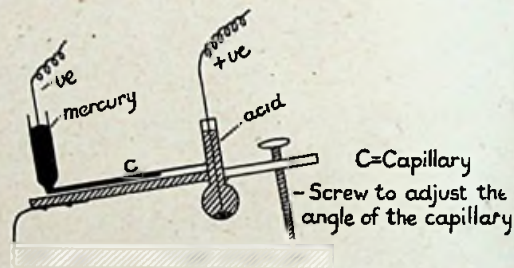

Fig 4b

invented, we see the necessity for immediate and intensive research on the subject. The amateur who equips himself with the apparatus described in this paper will find much interesting work to do, with the chance of making a discovery which will render television a much easier problem than it has been hitherto.

The next point which I should like to discuss is in connection with the results which I have obtained in my laboratory, using colloidal solutions, chief among which is colloidal selenium. This is an aqueous solution of selenium in which the particles are ultra-microscopic. It is, however, not a true solution, and for those readers who are sufficiently interested in the nature of colloidal solutions I would recommend the perusal of a book on Colloid Chemistry, such as may be obtained through most public libraries.

galvanometer which corresponds to a potential difference of 10-15 millivolts. This means that a colloidal solution of selenium is somewhat light-sensitive, and that with suitable adaptations it might be used as an

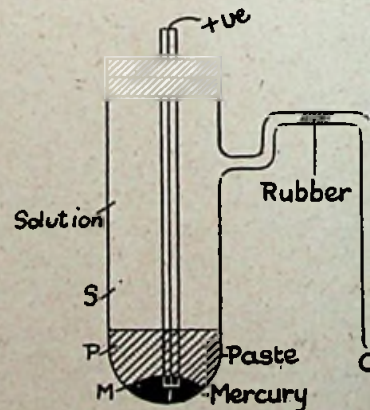
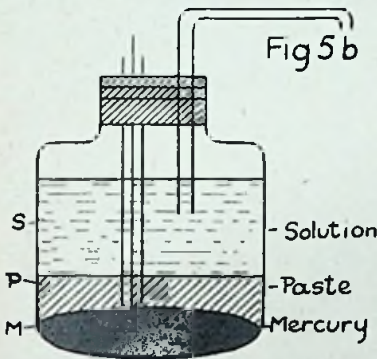

Fig. 5a.

"Electric Eye" in the television transmitter.

It is interesting to note that the surface area presented by the colloidal particles is very much greater than that of the substance in the solid state. For example, one gramme of selenium, when spread in a thin layer such as is employed in the cell described in the first number of this journal, would have a surface of about 30 square centimetres, while a colloidal solution containing the same weight of selenium can be shown by calculation (assuming the average size of the particles to be 5×10^{-6} cm. diameter) to have a surface of 200,000 square centimetres!

Further experiments have been or are being carried out with other colloidal solutions, such as colloidal



silver and gold, which can be prepared in a similar way to colloidal selenium.

A very dilute solution of silver nitrate has one or two drops of dilute ammonia added, and a cubic centimetre of tannin solution is poured in to the solution after it is heated to boiling point. A solution is then obtained which is brown to transmitted light, but green to reflected light, a so-called dichroic solution, in fact.

Finally, I would like to draw the reader's attention to the statements which appear in a contemporary, which say that Mr. Baird informs the correspondent of the paper in question that he uses a *light-sensitive device*, not a photo-electric cell. Taken in conjunction with remarks made to the author by Mr. Baird when demonstrating his televisior before the British Association last year, and the statement that he (Mr. Baird) had carried out experiments with visual purple (which contains a pigment called rhodopsin) we can see that a complete investigation of the subject of liquid light-sensitive cells is of vital importance.

(Concluded from page 15.)

seen in gorgeous rainbow colours, which are the component colours of white light. The sunlight falling upon a thin transparent film, such as a soap bubble, is reflected, partly from the first surface and partly from the second.

These two reflected beams pass in the same direction and mingle, with the result that certain colours depending upon the thickness of the film are eliminated by interference—a wave phenomenon by which, for example, beats between musical notes are produced. It results then that the thickness of a soap film at any spot can be determined by noting the interference colour occurring there.

Similarly, when a flat plate of glass is laid down on a standard optical flat the varying thickness of the film of air, occurring between the two plates, is indicated by different interference colours. In this way a depression in the surface being tested of a depth of the order of two one-millionths of an inch or less can be detected without difficulty.

Surfaces thus worked and then silvered, form what are known as "first-surface" reflectors. Sometimes the two surfaces of a plate are worked plane and parallel, in which case the back surface of the plate is silvered. The common looking-glass is made from silvered plate-glass, but its surfaces are neither plane nor parallel, so that it cannot be used for first-class optical work.

When reflectors are combined in optical action and it is important that they should be rigidly connected, the reflecting surfaces are generally worked as the faces of a solid prism of glass. In the prismatic binocular, for example, eight plane-reflecting surfaces are required, and these are worked in pairs on four solid right-angle prisms of glass. The necessity for silvering is thus avoided.

First-surface plane reflectors, made in the way described and with a diameter of several feet, are used for testing large telescope object-glasses.

In the next article in this series the subject of reflection by curved surfaces will be dealt with.

(Concluded from page 9.)

line working, and indeed it is unlikely that those waves which telegraphy will give up due to this competition will make any impression upon the voracious appetite of telephony.

It is only a couple of years since

we were up against the problem of how to fit in new services on the long waves available. Then came the short wave discoveries, which were hailed as solving the problem for ever; and here we are already coming up against the old problem again. It has not yet become acute, but it is quite time that those interested in all forms of radio communication should have a good look at the rocks ahead, and that those who are specially interested in television should satisfy themselves that reasonable provision is made in the ether for its experimental development and ultimately for its commercial application.

5 Catalogues FREE

THERE ARE OVER 250 "gadgets" and components shown in our catalogues. Many of these are suitable for use in Television apparatus and you cannot afford to be without them. Write for your copies to-day.

A. F. BULGIN & CO
9, 10, 11, CURSIOR ST., CHANCERY LANE, E.C. 4
TRADE MARK

LISENIN

POSITIVE GRIP TERMINALS ARE ABSOLUTELY IDEAL

(Patent No. 2,55386.)

The ends of the leads are so gripped that they cannot possibly come adrift. Pressure is so distributed that a break is practically impossible. (See illustration.) Further, the ragged ends of the flex covering are covered up, and one's leads look and behave as they ought to behave when fitted with Lisenin Positive Grip Terminals as used in

"RADIO FOR THE MILLION"

"AMATEUR WIRELESS"

"WIRELESS WORLD" SETS

AND BY LEADING SET MANUFACTURERS.

Follow the Lead of Experts. Insulated sleeves are made in standard colours, Red, Green, and Black. Plugs and sockets are interchangeable, and all metal parts N.-plated.

Liberal discounts to Manufacturers; samples gladly submitted to Trade enquirers.

THE LISENIN WIRELESS Co., 17, EDWARD ST., LONDON, W. 2
Phone Paddington 2741



Wander Plug.
Note taper.
2d.

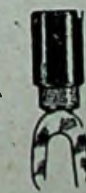

Spade End.
4d.



Plug and
Socket, 4d.



Socket and
Plug, 4d.



The Baird Television System in America

The Men who
Intend to
Commercialise It

MUCH has been written in the world's press about the personality and inventive genius of Mr. J. L. Baird, the first man to demonstrate television, and the man who is still entirely responsible for the technical development of this new science in this country.

In our last issue we were able to announce that the Baird Television Company had entered into an important contract with a very powerful American group, whereby the latter obtained certain rights for the exploitation of the Baird system in the United States, Canada, and Mexico.

Since that contract was signed we learn that a vast amount of organisation work has already been carried out, preparatory to the commencement of the commercial exploitation of the Baird system in America. The name of the new company is given as the Baird Television Development Corporation, with offices in New York, and it is planned to commence regular television broadcasting through American broadcasting stations next September. Simultaneously, Baird televisors will be placed upon the American market.

This development will synchronise with the marketing of televisors in this country, according to announcements which have just been made. The first televisors will be publicly exhibited in this country at the Radio Exhibition at Olympia, which will be held between September 22nd and 29th.

Interest is attached to developments in America because the man

behind the American television company, Mr. Charles Izenstark, has just arrived in London for the purpose of attending an international conference which has been convened to bring together all parties interested in the commercial development of the Baird system of television throughout the world. Elsewhere we give particulars of the international company which has made its appearance within the last few weeks.

Mr. Izenstark holds a most unique

position in the American radio world. He was a pioneer in the field of American radio as far back as 1915.

Besides being a very keen business man with almost unlimited means at his disposal, he has a most extraordinary personality which has endeared him to every radio manufacturer, jobber and dealer in the United States. This is saying a great deal when one is referring to such a vast territory, and even in such a land of surprises it is no mean feat



HERE FROM AMERICA.

Left to right:—Mr. Benjamin W. Sangor, who is financially interested in the new company recently formed in America to develop the Baird system of television in that country; Mr. Charles Izenstark, the powerful personality who intends to commercialise television in America; Capt. W. J. Jarrard, B.Sc., the representative in America of the Baird interests; and Capt. O. G. Hutchinson, joint managing director of the Baird Television Development Co., who met the Americans and Capt. Jarrard at Southampton. Our title picture shows the giant American liner "Leviathan" docking at Southampton.

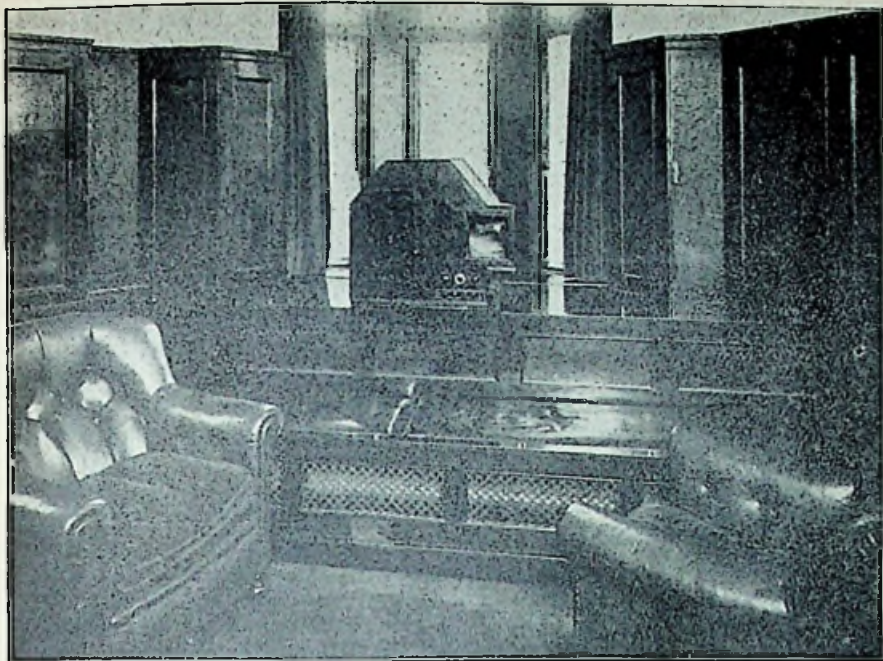

This photograph, published here for the first time, gives a very comprehensive idea of the appearance and size of the new Baird televisor in its commercial form.

to have attained a degree of such personal influence.

The secret of this success is Mr. Izenstark's unimpeachable integrity. He never lets anyone down, and is always ready to help a person in a difficulty. If a manufacturer wishes

to dispose of his stock speedily and without undue loss for any reason, "Charlie" Izenstark, as he is familiarly known to everyone in the industry, is the man who can do it.

In order fully to appreciate just what this means, it is necessary to

understand the enormous difference which exists between the radio industry in this country and in the United States. The radio industry in America is the third greatest industry in the country.

In this country we have a total number of $2\frac{1}{2}$ millions of licensed wireless listeners, and our population is about 40 millions. In America, where the population is 110 millions, and there is no broadcast licensing system, there are probably 20 million broadcast listeners. Wireless sets are now being produced on a mass production basis. The five-valve set is now out of date; only six- and seven-valve sets are being manufactured, complete with loud speaker and battery eliminators.

It is estimated that 3 million radio sets will be made and sold in America this year. One factory alone is turning out a seven-valve set, mounted in a handsome piece of furniture, at the rate of 180 *per hour*. The list price of this set is \$165 (about £33). The same set would have to be sold in this country for about £100.

Such figures are possible in America only because there is an enormous demand, and because every autumn, when the new season's model comes

It has now been definitely announced that Baird Televisors ("seeing-in" instruments) will be on sale in this country at the annual Radio Exhibition, which will be held at Olympia, September 22nd to 29th.

At the present time the Baird Company is exhibiting apparatus in Rotterdam.

Of special interest to our readers is the fact that Television Press Limited have taken a stand at Olympia for the Radio Exhibition in September. You will find us at Stand No. 11, Avenue A, just on the right as you enter the hall by the main entrance. Be sure and pay us a call. We shall have something of special interest for you.

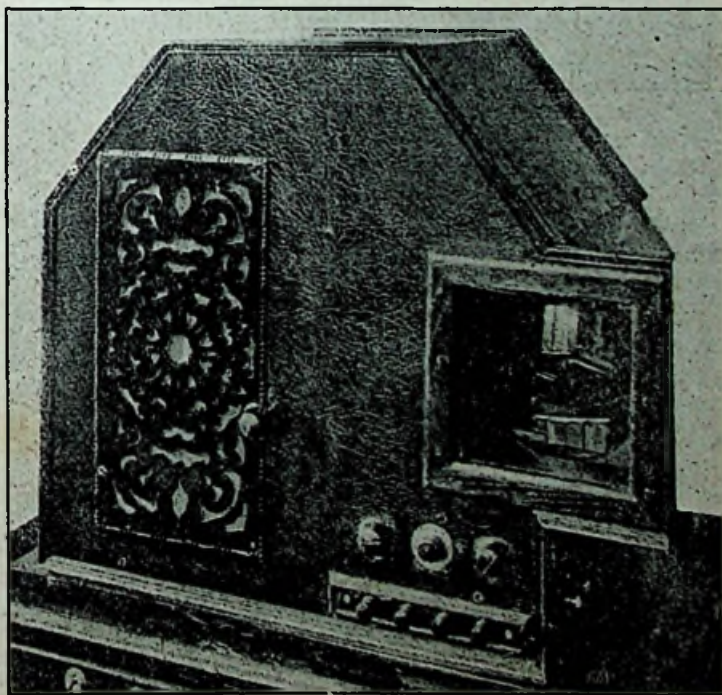

One of the several designs of the new Baird Televisor ("seeing-in" instrument) which will be marketed here and in America in September.

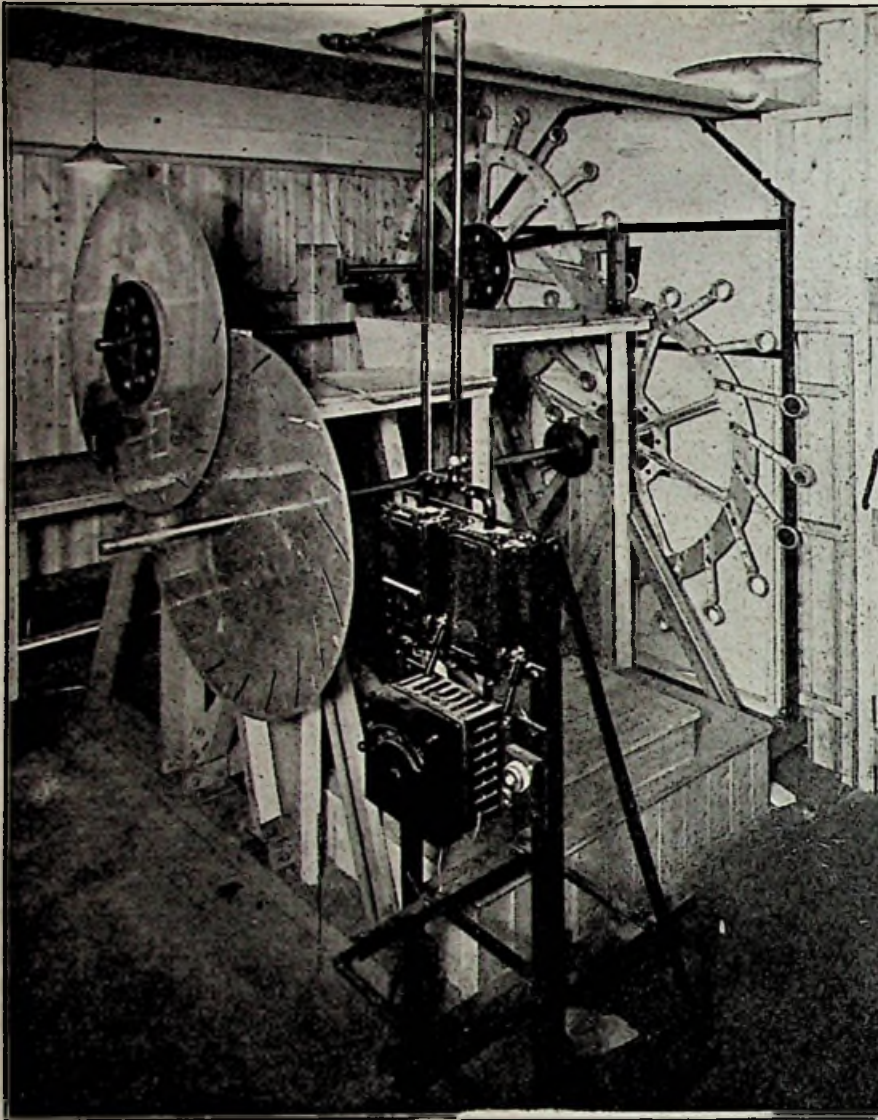

Above.

A hitherto unpublished photograph of one of the latest television transmitters in the laboratories of the Baird Television Development Co., which were recently visited by Dr. J. A. Fleming, F.R.S., who describes his impressions elsewhere in this issue.

On right.

Mr. Baird photographed at the controls of the new experimental wireless transmitter recently built on the roof of his laboratories.

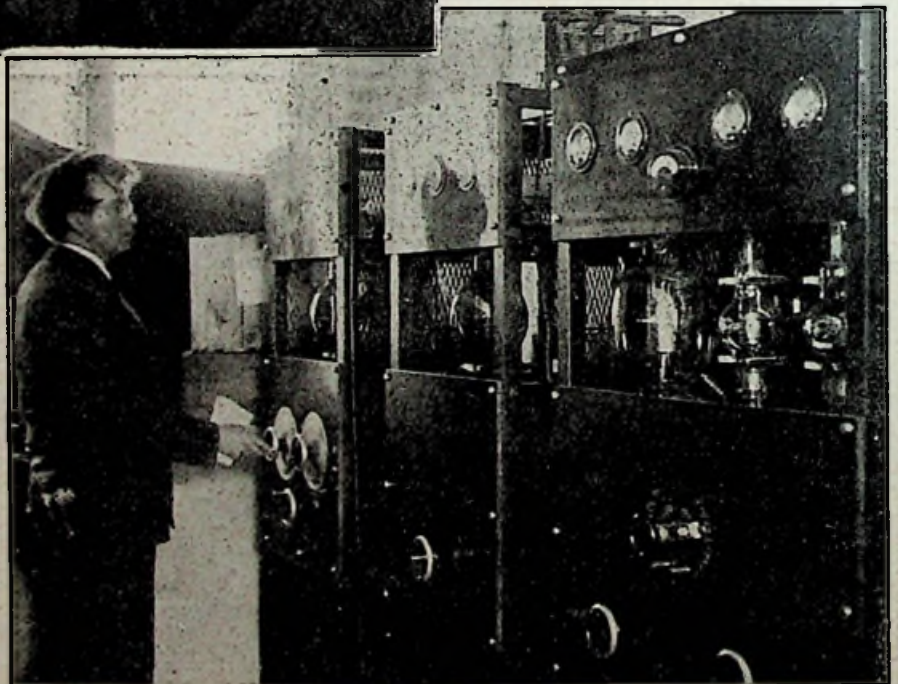

out, the buying public scrap their old sets and buy new ones.

Another interesting personality, who has also arrived here with Mr. Izenstark, is Mr. Benjamin W. Sangor, who is well known in America as a lawyer, a real estate operator, and as a financier. He is the founder of a new residential town called Pinewald, near New York, a vast estate covering 11,000 acres. This financial genius is working hand-in-glove with Mr. Izenstark in the business of commercialising television in America.

Mr. Izenstark, who is also known as the "Radio King of America," makes unusually free use of cables, wireless, and the trans-Atlantic telephone, in the conduct of his business. He invariably opens a telephonic conversation by announcing that "this is Charlie himself speaking." "Charlie" has a big personality, and it is personality which counts in American business to-day.

Here is a man whose connections and personal popularity extend throughout the entire ramifications of the American radio industry. This is the man who has announced that he intends to commercialise television in America—and will do it!

We venture to express the opinion that the Baird company have found in him and in Mr. Sangor the right men to do it.

Bridging Space

(Part I)

By JOHN WISEMAN

[This is the first of a series of articles in which the fundamental principles of electricity and wireless will be explained in the simplest possible language.—EDITOR.]

IN spite of the fact that there is a vast amount of literature on the subject of wireless, one is led to the conclusion, as a result of letters and personal enquiries, that as far as first principles are concerned there is still a great deal to be learnt. The publishing of TELEVISION has evoked enormous interest, but in order to grasp the facts more readily, and assimilate the knowledge imparted by this journal, it is incumbent upon readers to become acquainted with the elementary principles of cognate subjects. Since most of us will receive the television transmission via the medium of wireless, it is to that subject that we must devote a fair measure of attention.

Without pretending to do more than touch on the fringe of wireless principles, it is hoped that the information contained in this short series of articles will give a clear exposition of the important points involved, especially as attention will be directed right at the outset to "foundations," as by this means the reader can examine problems with a better understanding.

The Fundamental Nature of Things.

Many people, no doubt, have heard of the oriental race which, being very puzzled over the foundations of the universe, at length came to the conclusion that it must be supported on the back of a giant elephant. As for the elephant, they planted its feet on the back of a monstrous tortoise and there they let matters end. This short-sighted policy may be excused if we take into account the standard of reasoning employed by the race that can only think in terms of something quite tangible; but to-day our minds crave for some explanation of matter and energy, so we must turn to physics and chemistry; for between them

they have put together a conception of the fundamental nature of things which marks an epoch in the history of human thought.

"The Bricks of Our Universe."

We can grind a stone into powder or divide a spoonful of water into as many drops as we like, the process of subdivision going on as long as there is apparatus fine enough for the work; but obviously there must be a limit. We know to-day that matter is made up of *atoms*, the atom being the smallest particle of a chemical element. Although invisible it can be weighed and measured, but it is a comparatively new discovery that atoms are not indivisible; as will be shown later, they themselves consist of still smaller particles, but, even so, we can regard the atoms as being the "bricks of our universe."

Atoms do not, as a rule, exist apart from other atoms, but two or more come together to form a *molecule*. Furthermore, the solidity of our so-called solids is perhaps misleading. The hardest solid known actually is more like a lattice-work, although the molecules are not fixed like the bars of a lattice-work, but are in a state of violent motion, vibrations taking place about centres of equilibrium. If it were possible to see right into, say, a piece of steel, our gaze would be fixed upon billions of molecules, at some distance from each other and all moving rapidly to and fro.

The marvellous reasoning and delicate experiments employed in actually estimating the minuteness of atoms and molecules reads like a fairy tale, but it has been ascertained that the average molecule of matter is less than $1/125,000,000$ of an inch

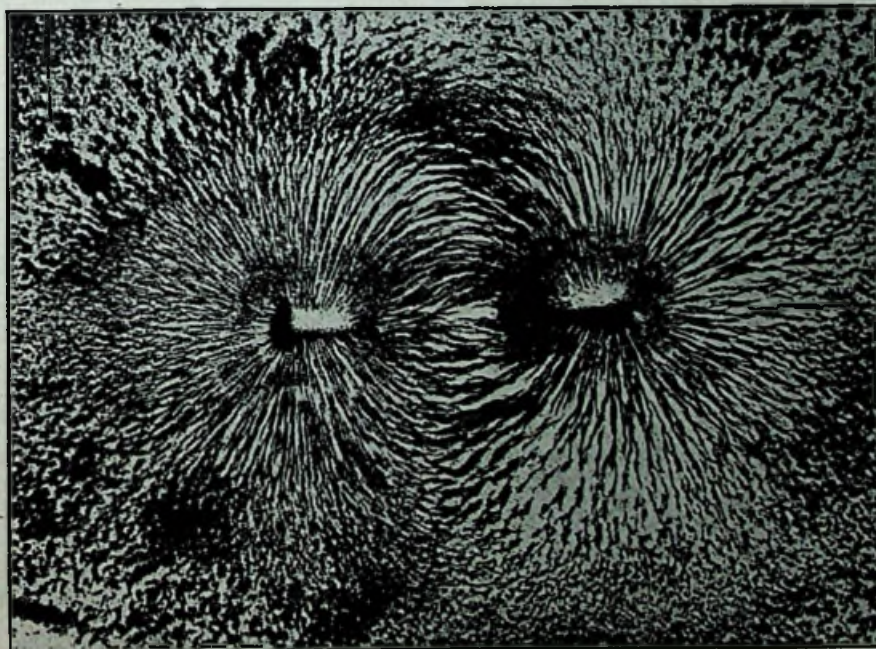

Lines of magnetic force photographed by the aid of iron filings.

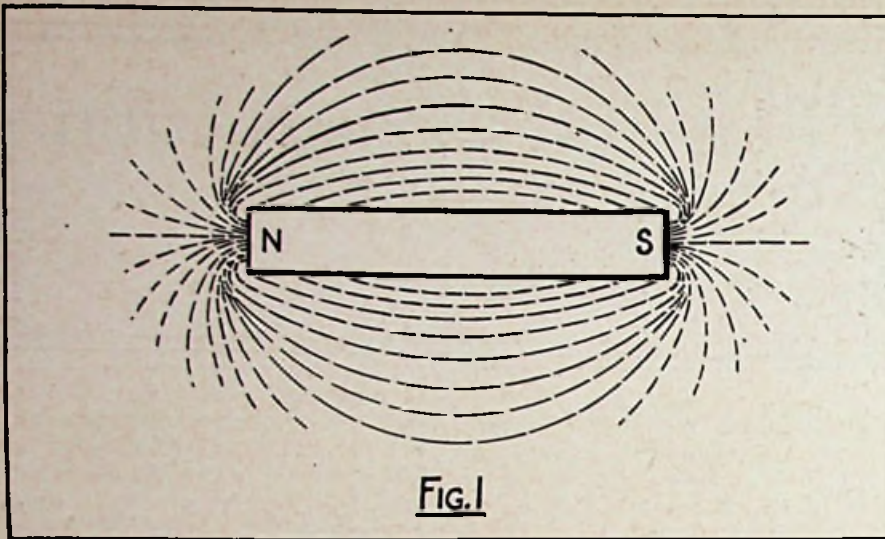

FIG. 1

in diameter. The atoms of matter have stupendous energy, and they vibrate or gyrate with extreme vigour. Now, readers may well ask whatever has this to do with wireless! As will be seen later, however, I am endeavouring to guide your thoughts into channels which deal with infinitesimal particles, for it is in this direction that we reach the fundamentals of wireless, as we shall see in a moment.

The wonders of the atom are only a prelude to the more far-reaching wonders of the *electron*. The experiments of Sir William Crookes on Electric Discharges in Vacuum Tubes were followed later by the discovery of X-rays by Röntgen. These are not a form of matter nor material particles, but a variety of light which possesses remarkable powers of penetration; and this clue to the mystery of matter brought about a search for something that was really super-radiant, culminating in Prof. Curie's discovery of radium. The enquiry was broadened and one substance after another was found to possess the power of emitting rays, i.e. to be radio active, and now, to-day, we know that nearly every substance can be stimulated to radio activity.

Radio Activity.

Radio activity really means that the atoms of the substance break up into smaller and wonderfully energetic particles which have been called electrons. These are really particles of disembodied electricity, and only when the electron was isolated from the atom was it recognised as a separate entity; but it can only maintain a separate existence if it is travelling at an

immense rate, at least 600 miles per second.

The physicist has not been able to find any character in them except electricity, but how electrons compose atoms is a scientific speculation. The theory which appears to hold most favour is that the electrons circulate round a nucleus, rather like the planets of our solar system revolve round the sun. It is further suggested that this nucleus is of positive electricity, attracting or pulling the electrons to it and so creating a state of equilibrium; otherwise the electrons would fly off in all directions. The nucleus is given the name of *proton*, and all matter, therefore, is nothing but a manifestation of electricity.

I have touched only lightly on these theories, in passing, as they have already been fully expounded in this Magazine* by one of the greatest living authorities on the subject.

Conductors and Insulators.

Now there is one manifestation in nature where this new thesis of electrons and atoms proves invaluable, and that is in connection with electricity. A current of electricity is now looked upon as a rapid movement of electrons from atom to atom in the particular conductor where the current is flowing. In a conducting material there occurs a constant interchange of electrons between neighbouring atoms, so that at any moment there are numerous relatively unattached electrons flitting backwards and forwards in all directions in the body, and if we apply any difference of

* See Dr. Fleming's article in our June issue.

voltage between the ends of the conducting material, say, for example, from an ordinary battery, there is caused a steady drift of dancing electrons from the lower to the higher voltage.

Of course, there is no resultant transference of matter through the body, because one electron is precisely similar to another, and they are led in at one part of the body at the same rate as they are withdrawn from the other. While some bodies permit this flow or movement, there are others just as stubborn as, say, copper is yielding, and to these we give the name *insulators*. The atoms of insulators part with electrons only under extreme conditions, and we call to mind such substances as glass, ebonite, porcelain, etc., as examples of this class.

Magnetic Properties.

Now, any electric current in the form of a flow of electrons produces or exhibits a magnetic effect. The surrounding space is endowed with what we call magnetic energy. The properties of a piece of magnetic iron are no doubt familiar to all, and many have seen the particular orientation of iron filings placed on a piece of card or paper over a bar magnet. They form certain definite paths, such as shown in Fig. 1, and actually illustrated in an accompanying photograph, giving the appearance of traced lines; and it is along these lines that we say the magnetic force exists, hence the term *lines of force*. A flow of current in

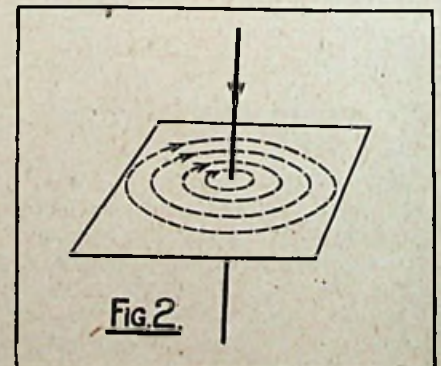

FIG. 2

a wire produces an exactly similar effect, as witness the arrangement of iron filings on a card through which is passed a conductor carrying an electric current. (See Fig. 2.)

At this juncture it is as well to point out a matter over which some people seem to get confused. According to the usual convention,

(Continued on page 30.)

The Marking Out and Construction of Spiral Discs

By Our Technical Staff

SINCE the articles dealing with the Simple Televisor have appeared, so many readers have written to us asking for further information on the methods of marking out and cutting spiral discs that it has been decided to devote a special article to a more complete description of this fascinating subject. It is proposed to give in some detail particulars for constructing discs which will give a finer grain and more detail than those specified in the original design.

A spiral disc consists essentially of a disc of thin sheet metal carrying one or more spirals of holes: these latter may be either round or, preferably, square. The holes approach nearer the centre of the disc as we go round the circle, the radial distance being decreased by an amount equal to the width of a hole each time.

Referring to Fig. 1, which shows a typical disc with one set of 12 square holes each $\frac{1}{8}$ in. square, it will be seen that the circumference has first to be divided into 12 equal parts. Radial lines are then drawn through the division marks. Now commence with any radial line, and with a pair of trammels or beam compasses strike an arc of a circle with the centre of the disc as centre, with radius, say, $\frac{1}{2}$ in. less than the radius of the disc, to intersect the selected radial line. Now decrease the trammels by $\frac{1}{8}$ in. (the width of the square holes) and strike another arc to intersect both this radial line and the next one, which will be referred to as the second radius.

Marking out Discs.

Again decrease the trammels by the same amount and strike an arc cutting both radius No. 2 and radius No. 3. Repeat the process, decreasing the trammels again and cutting radii Nos. 3 and 4. Continue to decrease the trammels and strike arcs until the disc has been traversed once completely. We now have a series

of radii each of which is intersected by two parallel arcs of circles $\frac{1}{8}$ in. apart, and to complete the marking out it is only necessary to draw short lines parallel to each radius at its points of intersection and $\frac{1}{8}$ in. away from it.

It will be seen that there are now 12 small $\frac{1}{8}$ in. squares, one on each radius: this should be quite clear from the drawing (Fig. 1) which shows this stage of the proceedings, the radii having been numbered to indicate clearly the order in which

they are marked out. The holes are, strictly speaking, not mathematically squared, since two of their sides are arcs of circles, but they approximate so closely to squares as to be indistinguishable in practice from proper squares.

Making Square Holes.

All that remains to be done is to drill small round holes in the centre of these squares, and to open the round holes up square by means of a square needle file, using a lens or

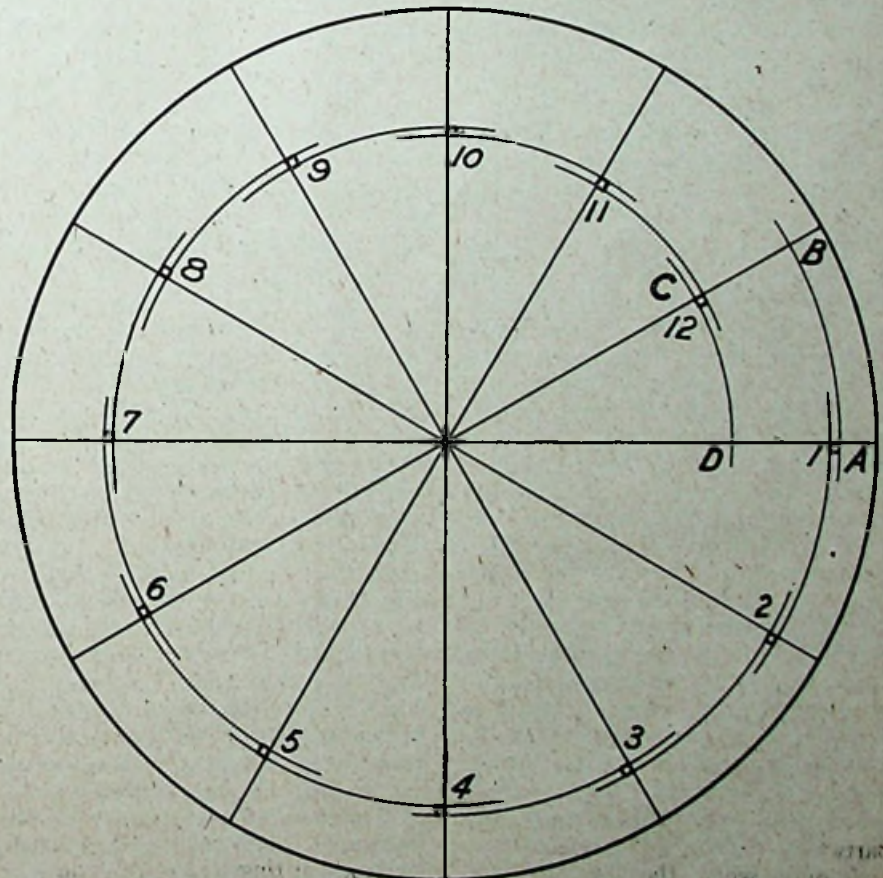

MARKING OUT FOR 12 HOLE DISC: DIAMETER 12"
HOLES $\frac{1}{8}$ " SQUARE.

FIG. 1. PICTURE AREA OF DISC—ABCD.

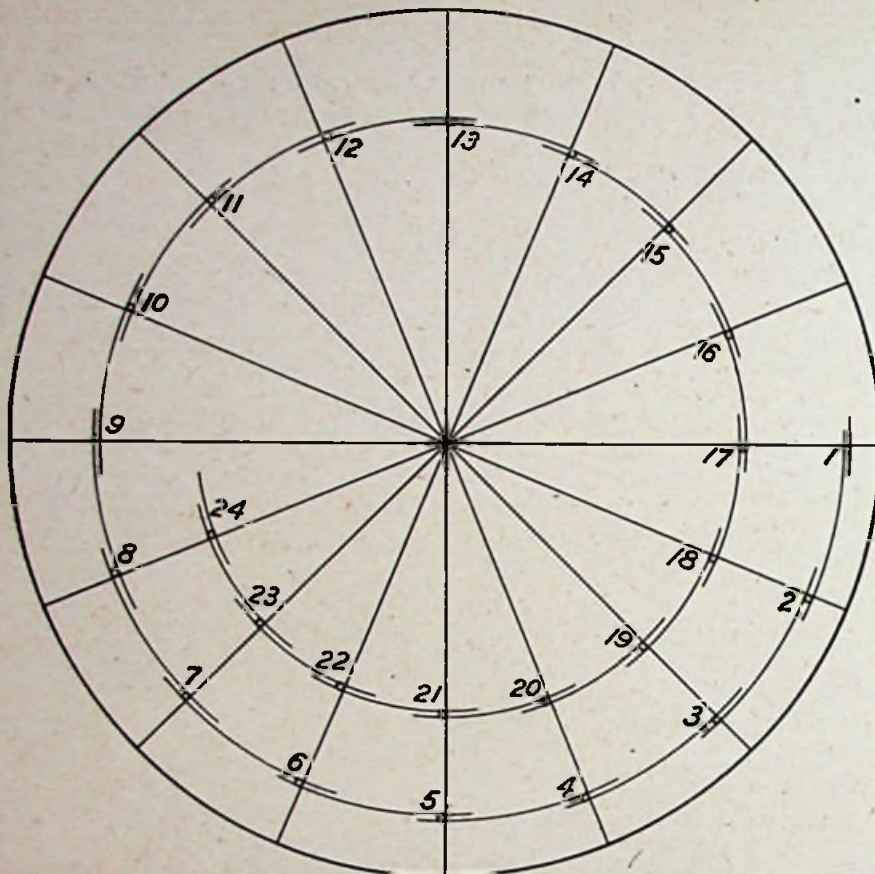

DESIGN FOR DISC RATIO $1\frac{1}{2}:1$
 DIAM. DISC—15". HOLES START $\frac{1}{2}$ " IN.
 SIZE OF HOLES $\frac{1}{8}$ " SQUARE.

FIG. 2.

specified, not by the total length of sensitive material on it, but by the length and breadth of the pictures which are to be taken on it, so a television disc is specified by the length and breadth of the received image, or by the ratio of length to breadth. Thus, a disc capable of giving an image $1\frac{1}{2}$ in. long by 1 in. broad, would have a ratio of $1\frac{1}{2}$ to 1, as also would a disc giving an image 3 in. by 2 in.

Disc Ratios.

Now, obviously, only one of our square stops must be within the picture area at any given instant, for if there were two we should have two points of the picture area having exactly the same brilliance (both being illuminated from behind by the neon tube), whereas there is only one initial signal. That is to say, two similar images would be formed. This phenomenon can actually be observed with the Simple Televisor by shifting the neon tube to various positions round the disc: there will be found to be a multiplicity of images arranged around the disc, though as the neon tube is taken further away from its correct position these images will be seen to be more and more displaced radially owing to the presence of what is known as a phase difference between the transmitted signal and the receiving disc.

This condition then determines the length of our picture, for it must be no larger than will lie between two consecutive radii of the disc. The breadth of the picture is obviously the distance measured radially between the inner edge of the innermost hole and the outer edge of the outermost hole. Referring to Fig. 1 we see that the picture area for this disc is represented in shape and size by the area ABCD. It will be seen to be not truly rectangular, so that the term "length of picture" is rather vague, but the usual convention is to consider the chord AB as being the length: then BC is the width of the picture and the ratio of the disc is AB/BC.

Refining the Grain.

In a previous issue it was suggested that better definition could be obtained from the Simple Televisor by using discs with a larger number of holes. A design for one is given in Fig. 2, which is drawn to scale.

(Continued on page 30.)

a watchmaker's eyeglass to ensure accuracy. Each hole must be filed exactly to the marked lines, and may be finished exactly to size by means of a small drift, if the reader cares to go to the trouble of making one.

For the benefit of those readers who are not acquainted with this simple tool a brief description will be given. It consists of a short length of hardened steel of square section, parallel for most of its length, but tapering slightly for the remaining portion. Each of the four faces has backed off cutting edges formed on it so that on placing the small end in the roughly finished hole and tapping lightly through with a hammer a perfectly square hole of exactly the correct size is formed. Note that the cutting edges are not cut squarely across the tool, but slantwise, so as to give a more even cut (see Fig. 3). The reader will find it quite easy to make these tools for himself out of short lengths of square silver steel, which may be filed to shape and size, after which the cutting edges may be formed,

and then hardened and tempered to a deep straw colour.

This completes the disc, with the exception of one rather important little detail which was omitted in the description of the Simple Televisor, namely, that since the material used is aluminium sheet, which is very highly polished and consequently reflects quite a lot of light, the disc must be coated with some form of dead black paint. The best kind to use is that known as acetate black, which has a cellulose in amyl acetate base, and which dries rapidly, leaving a very fine dead black surface. Care must be taken, however, that none of the holes are blocked up by it, and to this end it is advisable to pass the drift through all the holes again after the paint has dried.

We will now consider one or two theoretical points in relation to discs, with which the reader should familiarise himself, as they will occur frequently in future articles.

The most important point is what is called the "ratio" of a disc. Just as a reel of photographic film is

Natural Vision and Television

Part III.—Phenomena in Vision

By J. DARBYSHIRE MONTEATH

PERFECTION of natural vision must depend on the eye as a complete and perfect instrument. Even then the sensation of sight must be exactly interpreted. Professor Young, a pioneer in the study of vision, applied the mathematical formula of optics to the calculation of the various humours of the eye, and determined experimental data.

He noticed that the image of a candle or a star is not perfect in form, and attributes this to the irregularities in the refraction due to the fibrous structure of the crystalline lens, also that the eye is not truly achromatic. And to-day speculations are made on the supposition that the eye could make visible objects reflecting or radiating invisible spectrum rays.

If the infra-red gave the sensation of light the eye would see a halo around bodies in thermal equilibrium; but if ultra-violet rays were acting the body would be surrounded by a penumbra. So the conclusion suggested is that the apparent sharpness of some bodies is due to the structure of the retina, particularly

because vision is best in the yellow part of the spectrum.

The fact that vision is misled by refraction and reflection phenomena, as in mirage and the optical properties of bodies, makes interesting various experiments which we shall cite as additive to phenomena of vision.

It is well known that the image on the retina is inverted, but by a psychical act the field of vision is projected and inverted again to become erect. The inverted image is to be seen in the excised eye of an albino rabbit by holding the object in front of the cornea and observing the inverted image through the transparent coats of the eyeball.

The image observed at the receiving televisor is possible because the sensitive layer of the retina called the Bacillary layer, or Jacob's membrane, when excited by light does not cease to generate the sensation of light when the light ceases, or the stimulus is removed. So by persistence of vision images are built up and maintained, by the rotating slotted disc. We shall therefore give some attention to rotating discs and vision, and the production of after-images and recurrent vision.

Recurrent Vision.

The recurrent image of an electric spark was first reported on by Professor Young, who in 1801 became Professor of Natural Philosophy at the Royal Institution. He observed that after a spark had strongly illuminated an object it was seen several times again after the spark had passed and each time the image was fainter than the last.

The experiment is easily repeated. Screen the eyes from the spark of a Leyden jar and watch a white object, and in about a fifth of a second the recurrent image will appear. Watch on for a small interval and another

fainter image appears, and so on, till the phenomena is too faint to recognise.

Bidwell's Demonstration.

An interesting experiment due to Mr. Shelford Bidwell demonstrates this effect. Make a metal disc $2\frac{1}{2}$ in. diameter and pivot it so that it can be rotated as a lantern slide. Drill a small hole near the periphery. Focus the disc on to the screen and slowly rotate it so that the spot travels round the screen (see Fig. 1).

Now fixedly watch the image on the screen and it will be seen that a faint violet spot travels behind the white oval, which first appeared when the round hole was slowly moved. As the speed of rotation increases the interval between the spots increases, and as the speed slows down the two spots come closer together till they merge.

Now place a green glass in the beam of the lantern and the violet spot will appear more intense; an orange glass would make the violet appear less intense. Red glass in the

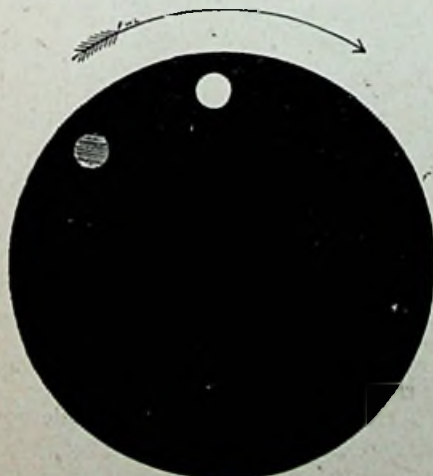

Fig. 1.

Illustrating the coloured ghost of a luminous image.



Fig. 2.

Charpentier's experiment.

beam extinguishes the ghost, for there would be no second hole in the red spot.

Charpentier made a special study

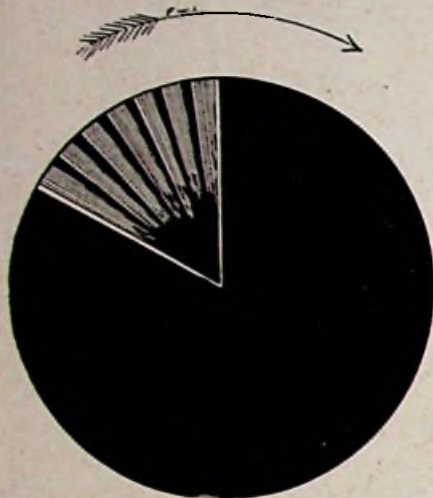

Fig. 3. Bidwell's confirmatory test.

of the impressions of light on the retina, and the following has been called Charpentier's law:—

"When darkness is succeeded by light the stimulus which the retina receives, and which causes the sensation of luminosity, is followed by a brief period of insensibility, resulting in the sensation of momentary darkness. It appears that the dark period begins about one-sixtieth of a second after the light has first been admitted to the eye, and lasts for an equal time. The whole alternation from light to darkness and back again to light is performed so rapidly that, except under certain conditions,

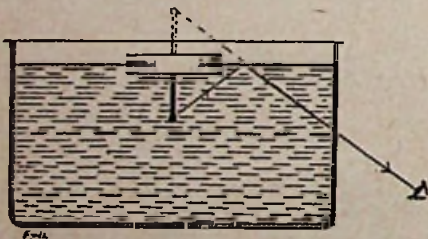

Fig. 5. Misleading the eye by total reflection. Although the pin's head is actually under water it appears to be in the air.

which, however, occur frequently enough, it cannot be detected."

Charpentier's Experiment.

Charpentier's experiment is easily repeated. Make a blackened disc with a white sector as in Fig. 2, mount it on a spindle, and rotate it slowly in sunlight. Closely watch the centre and there will appear on the

white sector, just behind the leading edge, a markedly darkened band. Now this dark band is construed by a portion of the retina, due to light reflected by the leading edge of the sector, which was recognised one-sixtieth of a second previously, according to Charpentier.

Bidwell succeeded in showing more of these dark bands (see Fig. 3), and concluded that the Charpentier effect begins at the period of illumination and is followed by a dark reaction at the end of the period. Further, Bidwell demonstrated that a black line diagram rotated behind a sector, cut out of a rotating disc, had the effect of producing a red sensation.

In other experiments he found that a bluish-green border appeared as the illumination was increased, and with a stronger light the red was replaced by a greenish blue. If the sector was rotated in such a way that the black part followed the aperture the red ceased to appear, and the lines appeared blue.

Experiments such as these prove conclusively that we must take into account the effect on the retina of a duration of light, and extra sensitivity due to darkness, and the intervals of darkness.

Benham's Top.

Many further experiments could be mentioned, but particularly of interest is the phenomena of vision involved in observing the spinning disc known as Benham's Top (see Fig. 4). When the disc of the top is rotated each group of black lines gives rise to a different colour sensation, and the line depends on the speed, and the brightness of illumination.

Rotate in the direction of the arrow and the outside set of lines appear red, the inside set will appear dark blue, and the intermediate lines produce a green sensation.

By illuminating the rotating top with monochromatic light mixed with white light from an arc lamp, very interesting colour vision phenomena may be observed.

So the study of vision will be helped by experiments. Indeed the development of natural vision has been along the lines of the creature's experimental experience.

Experiments on Total Reflection.

Take only simple cases of reflection or refraction, and it will be seen that some simple test is needful to check

the accuracy of judgments formed through vision. Rays of light may be totally reflected without being refracted, and the following experiment

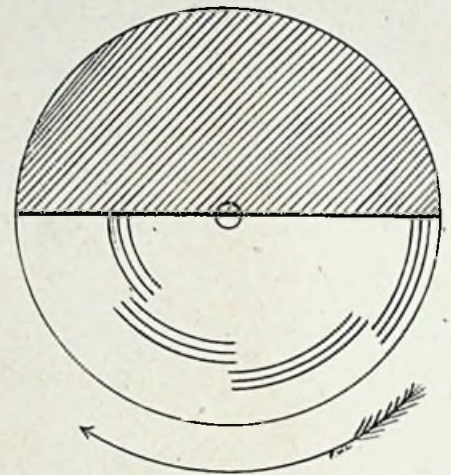

Fig. 4. Benham's Top, which demonstrates the production of colour sensations by means of rotating black lines.

confounds the popular reference that "seeing is believing."

Stick a pin in a cork, float it in water and place the eye above the level of the water. The pin will not be seen because all the rays from it that meet the water's surface will be totally reflected back into the water. Fig. 5 shows how the eye must be placed to view the pin, and the impression will be that the pin stands up in the air.

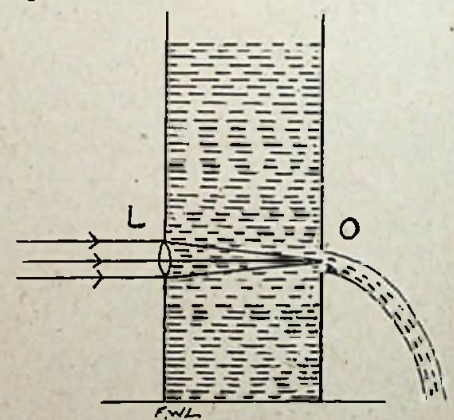

Fig. 6. Bending a ray of light by total reflection along a water jet.

Of the many ways of obtaining and viewing beautiful illustrations of total reflections, the illuminated fountain is a familiar example.

Practical applications are to be found in the bent transparent quartz, or glass rod, which is used to illuminate objects for the microscope, etc., and may very likely have its

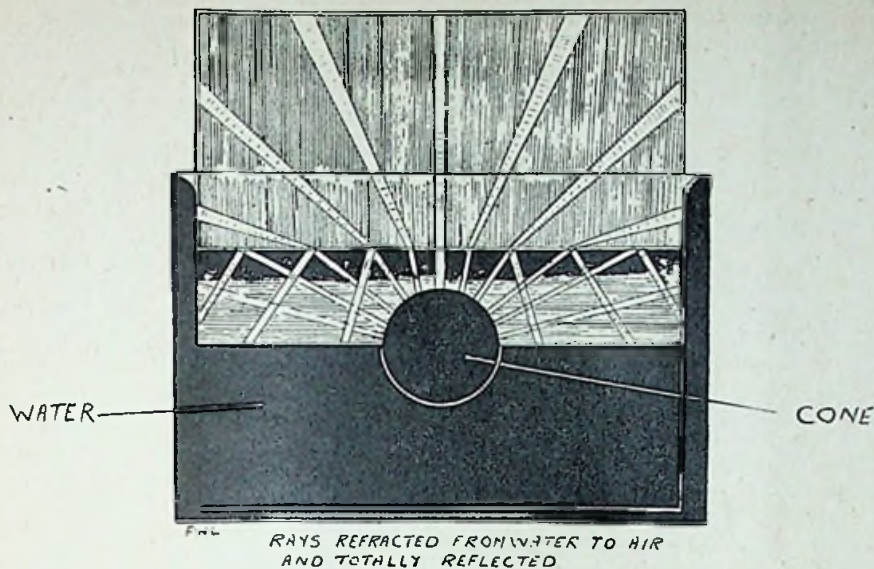

Fig. 7.—Refraction and reflection demonstration tank.

application in television transmissions.

Fig. 6 shows how light may strike the surface of a jet of water, or a solid bent reflector at an angle greater than the critical angle, when the light will be held a prisoner within the stream, or "conducting link." A glass held in the stream will appear to be filled with light.

But it would be hard to improve on the following piece of apparatus, should it be desired to demonstrate in an entertaining and convincing way the properties of refraction and reflection of light originating from the beam of a lantern. The beam is projected on a bright cone, shown dark in the centre of the tank of water; the beam will be reflected from the cone, and observed by placing in position a reflecting piece of tin, or nickel-plated zinc, shown at the back of the tank.

Fig. 7 illustrates a water tank, fitted with a plate reflector, made to slide up and down in the tank, so that the rays are seen due to refraction and reflection of light originating from the beam of a lantern. The beam is projected on a bright cone, shown dark in the centre of the tank of water; the beam will be reflected from the cone, and observed by placing in position a reflecting piece of tin, or nickel-plated zinc, shown at the back of the tank.

The apex of the cone should be turned towards the light and over the cone is placed a cylinder, blackened inside, which has slots cut, so that the cone reflected rays may be separated for observation.

As an application of the effects of refraction for vision the fish-eye photograph of Prof. R. Wood has an immediate interest.

Fig. 8 is a sketch from such a photograph and illustrates the impression a fish must have on looking upwards at the fisherman, and again suggests the importance of experimental tests and checks in forming conclusive judgments by natural vision.

In developing the perfection of television transmissions and reception



Fig. 8.

The world as seen through the eye of a fish.

all branches of physical and physiological optics must be explored; but particularly and fundamentally, reflection and refraction properties will be utilised, for the light values of a scene can only be dealt with by aid of the reflected light, and projection involves the principles of refraction.

At the receiving end the phenomena of vision asserts itself and is indeed the basis of television reception.



MODEL C14.

The finest Gift

As a gift "Celestion," most excellent of Loudspeakers, is without a peer, for all who hear it can share the great pleasure that it brings. Get your dealer to demonstrate "Celestion" for you. You will be amazed at its realism.

Embodied in "Celestion" are the six essentials of an excellent Loudspeaker.

These are:—

- EVEN RESPONSE
- EXTREME SENSITIVITY
- ONE ADJUSTMENT
- IMPERVIOUS TO CLIMATE
- IMPROVEMENT WITH AGE
- DISTINCTIVE APPEARANCE

Moreover, "Celestion" is British made throughout.

Made under Licence.

There are four "Celestion" models in oak or mahogany ranging from £5 10s. to £25. We shall be glad to forward to you our free illustrated literature giving full particulars, and of our "Woodroffe" Type Gramophone Pick-Up. When ordering please state whether adaptor is for H.M.V. or 3 inch size.

CELESTION

The Very Soul of Music

Write to Dept. T.V.

THE CELESTION RADIO CO.
Hampton Wick, Kingston-on-Thames.

Showrooms:

33/35, VILLIERS ST., LONDON, W.C.2.

Affiliated Company:

CONSTABLE & CO., PARIS.

(Concluded from page 24.)

we see a current shown as flowing from the point of positive potential (or voltage) to the point of negative potential (or voltage). From our recent acquaintance with the electrons, whose movement constitutes the current, we see this is actually wrong, for the electrons, being themselves particles of disembodied negative electricity, are naturally attracted to the positive potential, and, in consequence, the flow or drift of electrons when a current is established in a wire is diametrically opposite to the conventional method of illustrating the flow. (See Fig. 3.)

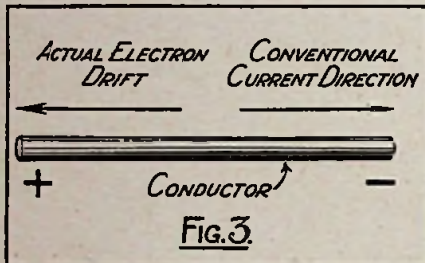

Electric and Magnetic Effects Interlinked.

Reverting to our previous train of thought, we see that there is a disturbance set up in space by the current flow, and even a single electron, when in movement, creates a magnetic field around its path. The two are interlinked in an indivisible manner, and it is at this point that we come to a more direct relationship with wireless.

Wireless, as we know it to-day, is not one of those sudden discoveries. It is due to purely scientific work over a period of years, just the same as television. We have seen that a current of electricity flowing in a wire produces a peculiar condition inside the conductor; but it has also been shown that the space surrounding the wire has remarkable properties, and the essential characteristic of wireless transmission or, to give it its more technical name, *electro-magnetic radiation* is to direct attention not so much to the electric bodies themselves as to the space surrounding them.

From our previous remarks it is clear that any body charged with electricity has lines of force radiating from it, these electric lines of force being similar to the magnetic lines of force emanating from the magnet.

As we shall see next month, this is the foundation of the waves used in ordinary wireless transmission.

(Concluded from page 26.)

It will be noticed that a spiral is shown which extends one and a half times round the disc. The purpose of this is as follows.

The early combined transmitting and receiving machine was fitted with a disc having two spirals arranged consecutively round the disc, so that while one set was being used to analyse the shadowgraph at the transmitting side the other formed the image at the receiving side.

In the disc shown in Fig. 2, however, holes Nos. 1 to 16 inclusive are used to analyse the shadowgraph, while Nos. 8 to 24 inclusive form the image at the diametrically opposite side of the disc. Masks are arranged accordingly at the transmitting and

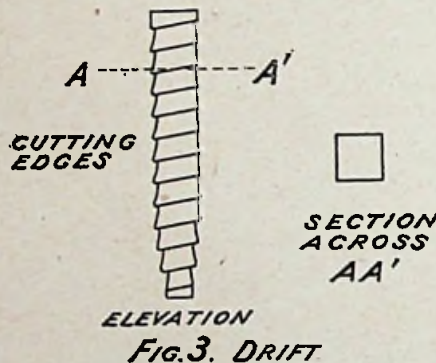

receiving sides, so that this is the case always.

If the reader has constructed the separate synchronised receiver he should make two similar discs, only cutting the first 16 holes, since one disc will be used on the transmitter and one on the receiver.

The difference of grain between 10 holes and 16 is quite surprising, and with these discs a much finer image is obtainable. The discs are 15 in. in diameter, and the first hole starts $\frac{1}{2}$ in. only from the periphery, the holes being of such a size as to give a picture with a ratio of length to breadth of $1\frac{1}{2}$ to 1.

It should be explained that there is no particular merit in the diameter being 15 in., as it might just as easily be 20 in., or any figure the reader may care to use, but care should be taken to make the holes larger in proportion. Also, while we have shown 16 holes, the amateur will find it extremely interesting and instructive to design and construct discs of varying ratios and in varying numbers of perforations.

A New Television Company

On June 25th a new television company, called the Baird International Television, Ltd., was floated with a capital of £700,000, divided into 1,400,000 "A" shares, having a nominal value of 5s. each, and 1,400,000 "B" shares of the same nominal value.

The "B" shares were issued as fully paid to Television Limited, as vendors, in consideration of their assigning to the new company 300,000 fully paid Deferred Ordinary shares of 1s. each in the capital of the Baird Television Development Co., which has an issued share capital of £125,000. The current market value of these shilling shares is in the neighbourhood of 30s. each. The new company also acquires from the vendors 33 $\frac{1}{3}$ per cent. of the net proceeds, whether in cash, shares, or other securities, payable to the vendors in respect of the sale and exploitation of the foreign and colonial rights of the Baird inventions, the Baird Television Development Company being entitled to the remaining two-thirds of such net proceeds.

The public were given an opportunity of subscribing to 1,000,000 "A" shares at a premium of 1s. each, and the issue was very heavily over-subscribed, the list closing at 10.30 a.m. on the morning of issue.

The Chairman of the new company is:—

The Rt. Hon. LORD AMPHILL, G.C.S.I., G.C.I.E.

Other members of the Board of Directors are:—

Sir EDWARD MANVILLE, 3, Whitehall Court, Westminster, S.W., Chairman of Baird Television Development Co., Ltd.; Chairman, Daimler Co., Ltd.; Director, Royal Exchange Assurance.

Lt.-Col. GEORGE BLUETT WINCH, Boughton Place, Maidstone, Kent, Chairman of Style and Winch, Ltd.

JOHN LOGIE BAIRD, 975, Finchley-Road, London, N.W., Inventor and Joint Managing Director of Baird Television Development Co., Ltd.

OLIVER GEORGE HUTCHINSON, Combermere, Hillsborough, Co. Down, Ireland, Joint Managing Director of Baird Television Development Co., Ltd.

(Continued from page 16)

stration, that as far as possible we have avoided the use of delicate or complicated measuring apparatus; we have kept to the simplest ideas throughout in arranging the demonstration, and that as regards measuring apparatus we have nothing more sensitive than a milliammeter reading from 0-5 milliamps., in tenths of a milliamp.

In the course of my remarks I shall frequently use the unit milliamp.

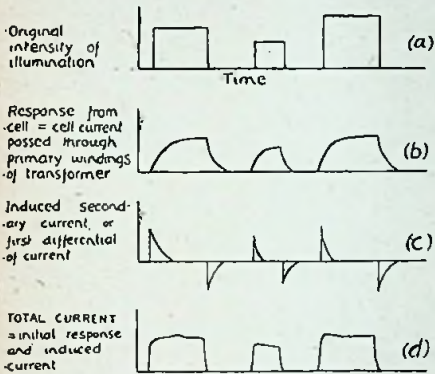

Fig. 1.

Curves illustrating J. L. Baird's method of utilizing the first differential current of the initial cell response.

Now, a milliamp is the one-thousandth part of one ampère; a microamp is the one-millionth part of the ampère. Usually the quantities involved are microamps, and require very sensitive galvanometers or electrometers for their detection in the laboratory.

First of all I will deal with the selenium cell, and later, after the demonstration of the selenium cell, we will turn our attention to the photo-electric cell, bearing in mind that as far as possible I want to illustrate results, and how to obtain results, rather than to discuss the theories and principles involved, following the analogy that one rides a bicycle or drives a car before attempting to pull either to pieces.

Photo-Conductivity and Photo-Emissivity.

Selenium cells depend for their action on the well-known property of selenium that it changes its electrical resistance when exposed to light, and it may be said at once that with the modern cell, quite appreciable readings, amounting to *milliamps* of current, are available when a potential of the order 60 to 70 volts is used across the terminals of the cell. In using photo-electric cells, on the other hand, unless special methods are

used (which it is my intention to indicate later in the course of my remarks) we shall find we are dealing with *micro-amps* of current, and means have therefore to be taken to magnify the otherwise small changes of current which represent changes in light intensity.

Unequal Response to Different Wave-lengths.

Both types of cell, however, have one property in common, and that is that they do not respond equally to light of different wave-lengths. Selenium, for example, is almost unresponsive to light rays outside the range of the visible spectrum. (A slide was used to illustrate this.) The potassium cell is most sensitive in the blue and violet part of the spectrum up to wave-lengths of 4,400 Angström units; an Angström unit being one-hundred-millionth of a centimetre. The sensitivity of the potassium cell approximates almost to that of the ordinary photographic plate. The finished potassium cell, of which we have a specimen on the lecture table, is recognised by its bluish colour. A rubidium cell, which is greenish in colour, is sensitive up to about 4,800 Angström units; while the caesium cell, which is yellow in appearance, is predominantly sensitive to yellow light up to 5,500 Angström units.

Covering the Visible Spectrum.

Thus we have three cells for use within the range of the visible spectrum. Outside of the visible spectrum we can use either lithium or sodium cells for ultra-violet light and thalo-sulphide cells for the infra-red region. Inter alia, it might be mentioned here that the sensitivity of most cells is unaffected by the working temperature, within ordinary atmospheric limits.

The selective current produced by light of different wave-lengths, or in other words the colour sensitiveness of the cells within the range of visible light; suggests that ultimately a use might be found for combining the three different types of cell in colour picture television.

Another very practical problem which arises very early in television systems is that the quantity of light reflected from a surface is usually many hundred times less than that obtained by direct illumination, as we shall hope to show in another part of our demonstration. As we

are not concerned with the transmission of silhouettes, the problem enters into all transmission by true television. In consequence of this the light-spot method, and the Alexander seven-spot method have been devised and successfully used for avoiding the intense glare and consequent discomfort to the person being "televised."

The suggestion has been made by Baird and Ives whereby an exploring beam of ultra-violet and infra-red rays are used simultaneously. As will be seen from the slide (see p. 13, April TELEVISION) these rays are both outside the visible spectrum. Two kinds of cells are used, the object being irradiated with these invisible rays for selective effects, and the relative effects of the two kinds of cell can be adjusted to give just the right tonal value to the picture or scene being transmitted.*

Selenium Cells.

The most familiar form and also the most sensitive form of selenium cell is that known as the "Condenser" type, consisting of a number of flat plates separated by mica insulation. A thin layer of selenium is then fused on to one edge of the bank of condenser plates.

In the flat wire type of cell, one bare or uninsulated conductor and one covered or insulated conductor are usually wound bi-spirally on a flat tablet or slate of insulating material.

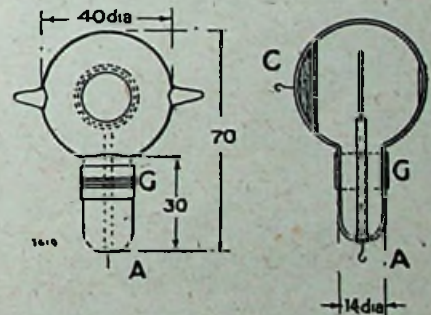

Fig. 2. Dimensions (in millimetres) of the Lindemann Cell.

These conductors are arranged alternately and closely against each other. In order to increase the capacity of the cell the conductors are usually of slightly different diameters, the insulated conductor being the larger of the two.

In preparing the cell the insulation is first removed from the outer top surface of the wire-wound block, and a thin even layer of selenium spread

* See TELEVISION, June, 1928, page 32.

over. It is very important that an even layer of selenium should be present (so that a mass is not located at any one point of the cell) if the cell is to give consistent readings. In the grid pattern thin lines of heated selenium are painted across a piece of glass or other insulator, the two ends being retained in a clip.

The Condenser Type of Cell.

For sensitivity and general ease of working, the condenser type is very efficient. The important point is that we must remember to arrange for the greatest change in resistance to occur when the cell is removed from darkness and exposed to light, so that varying quantities of light falling on the cell produce correspondingly large variations of current through the cell.

I have made a number of tests on different cells of the condenser type. Using the illumination from a 500-watt lamp at one metre distance, with no lenses or reflector, the mean of several tests gave:—

Dark resistance: 2,000,000 ohms, current 2 micro-amps. Light resistance: 300,000 ohms, current 12.5 micro-amps.

giving a ratio dark/light resistance 2,000,000/300,000 equals 7, nearly. With the light source 12 inches away from the cell the values were, for resistance, 125,000 ohms, and for current passed 33 micro-amps., giving a ratio of dark/light resistance equivalent to 16. The need for some kind of standard test is obvious. That usually taken is the ratio dark/light resistance from a source 76 mm. (3 inches) distant, using a 60-watt tungsten filament lamp.

Increasing Sensitivity.

The sensitivity can be increased by using a Wheatstone bridge* arrangement using four cells and keeping two cells in opposite arms of the bridge in the dark and two in the light. By "dropping" part of the potential along the two arms of the bridge in the usual manner we have a very greatly increased sensitivity. I suggest this arrangement, or modifications of it, as a suitable and profitable subject for further experiment.

These cells have many uses other than in television. They have been

* For balanced bridge methods, see "Journal Scientific Instruments," Vol. 1., page 56, 1923.

used successfully in picture transmission and in automatic lighting systems for such purposes as lighthouses and street lighting, where they are particularly useful during fogs or a diminution of daylight, for they are automatic in their action. They have also been tested for the transmission of speech by light, as in the speaking film, and they have many other uses in those branches of science where precise measurements are required.

But in all these applications which have been mentioned, the presence of a slight "time lag" is comparatively unimportant. In television any lag is of vital importance.

When it is required to detect extremely small variations of light, the question then arises as to whether the

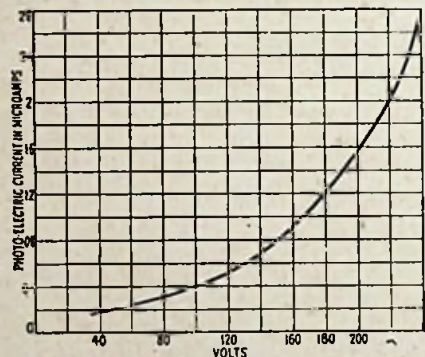

Fig. 3. Sensitivity Curve of a Lindemann Cell.

cell can faithfully follow very rapid variations, or whether it suffers from "lag," or, shall we rather term it, "inertia." The matter is not easy when it comes to measurement, more so in the case of the photo-electric type of cell, because apparent inertia is very easily introduced by the very apparatus used for amplifying the variations of photo-electric current. This apparatus usually comprises amplifying valves.

At the present time there seems to be no evidence that photo-electric cells in themselves possess any appreciable inertia even at frequencies of 5,000/sec. In the case of selenium cells, it has been shown by Dr. Fournier D'Albe† that with a light-signal lasting no longer than 1/1,000 sec. a relay can be controlled by the response from a selenium cell, so that the "lag," if it does exist, is not excessively large, but probably too large to be easily overcome in practical television.

† Address to Oxford University Radio Society, March 10th, 1926.

In order to overcome difficulties of time lag in cells J. L. Baird suggests‡ a method of utilising the first differential current of the initial cell response. Using a transformer of high ratio, the primary windings of the transformer carry the initial cell response current, the secondary windings carry the differential current, both windings being connected in parallel in such a manner that the secondary current is in effect additive. When this is done, using a transformer of suitable ratio, the resulting intensity curve (d) (Fig. 1) more nearly approximates to the original curve (a) for light impulses of longer duration than curve (b), which is the initial cell response. When the duration of individual light signals being dealt with is substantially less than the time lag of the cell, a current proportional to the current through the secondary windings or the induced current (c) at its maximum value may suffice to overcome the effects of "lag."

The First Demonstration.

A demonstration was then given. A selenium cell of the condenser type was used connected as shown in the wiring diagram (Fig. 11). A voltage of 100 was used on the cell, and illumination was provided by (1) direct rays from an ordinary 100-watt tungsten filament gas-filled lamp, and (2) by indirect illumination from a bank of six 100-watt lamps of the same type. A milliammeter showed the steady current through the cell in the dark (0.35 milliamps) and the increase in current to 0.9 milliamps when the direct rays from the 100-watt lamp at 3 inches distance was allowed to fall directly on the cell.

A motor-driven "interrupter" disc was then set in motion between the cell and the source of light at an estimated speed of 30 revolutions per sec., i.e., so that the light was "chopped" 1,500 times a second. The response current from the cell was amplified through a standard Western Electric two-stage L.F. amplifier, the voltage and all controls of the amplifier being kept constant throughout the demonstration. On moving the 100-watt light source further away from the cell the note in the loud speaker became fainter, illustrating the inverse square law. Placing the hand or an opaque object in the direct line of the illumination showed a very clean

‡ Patent No. 270222.

"cut-off" of signals on the loud speaker. Using indirect lighting from the bank of eight 100-watt lamps, and holding different reflectors at an angle of tilt of approximately 45 degrees, the following results were noted:—

planets, etc., as has already been done by General Ferrié and Professor Lindemann, of Oxford. Also it is quite feasible to use a number of photo-electric cells in parallel, as was actually done in the American

The cells are fitted into a light-tight box with shutter and variable aperture.*

Sensitivity Curve.

The next slide (Fig. 3) shows a sensitivity curve, or voltage plotted against current for an average cell when exposed to illumination from a 100-watt tungsten gas-filled lamp at 7 cm. distance. It will be noted that the sensitivity increases four-fold between 100 and 200 volts potential the slope at 200 volts being about 2.3 per cent. per 2 volts difference of potential.

When measuring moderate light intensities the current may be measured by a high-resistance moving-coil galvanometer G_1 (Fig. 4) connected as shown in the slide. The cathode of the cell is connected to the driving potential, the anode to the measuring apparatus. It is usually not necessary to make use of the guard ring unless leakage is suspected, and this connection is shown dotted in the diagram. A resistance R , which may conveniently be an R.I. Varley wire-wound resistance of about 50,000 ohms, should be inserted between the cathode C and the high-tension supply to protect the cell. For high-tension supply I have found the Sac Wet Leclanche type of battery extremely efficient and very steady in operation. In general it is

Light Reflectors.

Response of Cell.

Test: (1) White "Whatman" drawing paper.	Result: Sound about equal in intensity to direct illumination of the single lamp or slightly louder.
(2) Black paper taken from photographic plates.	Result: Very feeble signals.
(3) Hand placed against black paper.	Result: Distinct increase of signal strength on test (2).
(4) White "Whatman" paper with black paper masking about one-half of the white surface.	Result: Greater than (3) but less than (1).
(5) Pink-coloured cartridge paper.	Result: Almost equal to (1).
(6) Silvered paper	Result: Not quite equal to (1).

It was assumed that the speed of the motor driving the interrupter disc remained constant throughout the demonstration. Care was taken to shield any direct rays from the bank of lamps from reaching the cell, although this was not quite successful. By altering the angle of tilt of the reflector, changes in the intensity of the signals were apparent on the loud speaker. The selenium cell showed no response to ultra-violet rays produced by a Chance's ultra-violet glass screen.

Telegraph and Telephone television demonstration last year.

On the screen we have a slide (Fig. 2) showing dimensions of the type of photo-electric cell devised by Professor Lindemann at the Clarendon Laboratory, Oxford. In this cell potassium is deposited in a sensitive colloidal form on the silvered walls of a suitably shaped glass vessel which is afterwards filled with an inert gas. The electrons emitted when the light falls upon the cell are caught on a ring-shaped anode within the tube and the current (which is proportional, but not *directly* proportional to the incident light) is carried to a suitable measuring instrument. This current can be greatly amplified, and in fact this is always done in practice, by using an accelerated driving potential, which causes ionisation by collision in the rare gas with which the cell is filled at an appropriate pressure.

Photo-electric Cells.

The action of photo-electric cells depends upon the fact that light falling upon a metal surface causes the metal to emit electrons. The emission of negative electricity from an illuminated plate is now called the photo-electric effect, or sometimes the Hallwachs effect, Hallwachs being the first to investigate it. It is important to bear in mind that the number of electrons leaving an illuminated metal surface is strictly proportional to the total amount of light falling upon it. The number of electrons released is quite independent of whether the image is a point source or an extended surface.

In other words the current produced is proportional to the amount of the incident light, and is entirely independent of the intensity per unit surface. This fact makes it possible to compare *very accurately* the light from stars with that from extended objects such as comets, nebulae,

Leakage is prevented by guard rings consisting of a strip of tin foil wrapped around the outer surface of the cell, and a platinum wire ring around the inner surface. The two rings are connected together and maintained at the potential of the measuring instrument. The cell is fitted with a window (20 mm. diameter, 20 mm. radius of curvature) which allows the greatest amount of light to enter the cell. This fact probably accounts for the very small amount of reflected light which reached the cell during the demonstration, in spite of careful shielding.

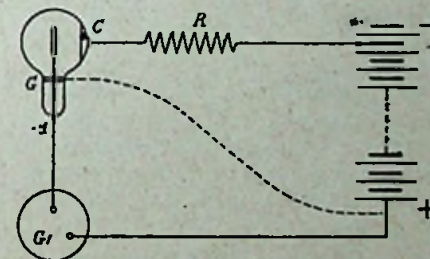

Fig. 4. Circuit for measuring Sensitivity of a Photo-Electric Cell.

safe to use a potential up to 200 or even 250 volts, but the actual potential at which a glow-discharge occurs depends to some extent upon individual cells.

Approaching Glow Discharge Potential.

An indication that the potential for glow discharge is being approached can be gained from the sensitivity-voltage curve. When the sensitivity

* Technical details of the Cambridge Instrument Co. cell are given in "English Mechanics," July 17th, 1925.

doubles itself with an increase of, say, 10 volts, it indicates that glow discharge is about to take place, and it is inadvisable to raise the voltage

potassium runs down into the bottom of the cell and flows round the cathode K at 6. The cell is then sealed off at 5 and the potassium must

from the older type of vacuum cell where a thin layer of potassium, sodium, or rubidium is deposited by condensation from vapour. In vacuum cells the silvered surface on which the alkali metal is deposited has not been sensitised by the Elster-Geitel method of a discharge in hydrogen. The cells are completely evacuated. These vacuum cells are useful only when the incident light has to be measured accurately, and they are not suitable for tracing rapid variations of light.

A vacuum cell, when receiving illumination from a 60 watt gas-filled lamp with its filament 15 cm. from the cell, will give a current of the order of 1/100 microamp. The gas-filled type under the same conditions will give several hundred times as much current of the order 10 microamps. It should be made clear that in vacuum cells the current passing through the cell is that liberated by the direct action of the light on the sensitive cathode. In gas-filled cells this current is greatly magnified by the passage of the electrons first released from the sensitised surface as they pass through the gas, and as they proceed they form secondary electrons by collision.†

Illustrating process of manufacture of Lindemann Cell.

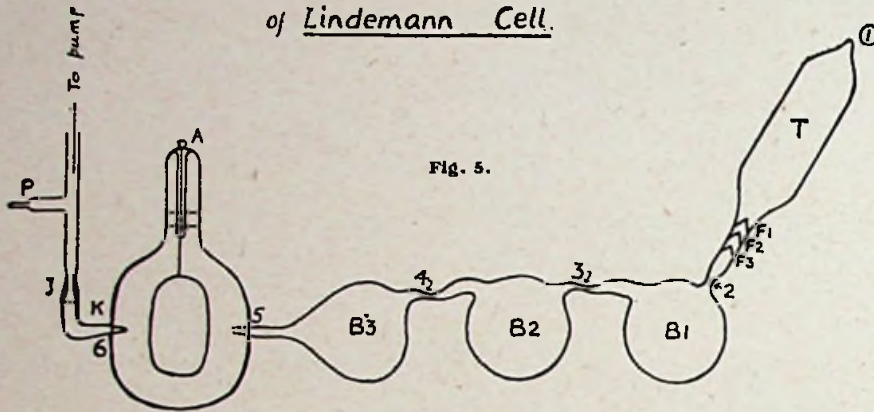

Fig. 5.

much further without caution. The point where a discharge passes through the cell is accompanied by a purple glow which is almost independent of the amount of light; the current does not vanish when the illumination is cut off. This point therefore represents the greatest voltage which can be applied to the cell, and the greatest amount of current that can be obtained with a given amount of light.

When it is attempted to amplify the photo-electric current by means of a valve amplifier, it is found that the amplification falls off considerably as the illumination increases, i.e., the amplification is greatest for small initial currents. Although the photo-electric current is proportional to the illumination, the amplified current is by no means linear, and the form of curve varies from valve to valve.

Method of preparing Cell.

The potassium is cleaned and freed from paraffin as far as possible before being introduced into the tube T which is then sealed off at 1 (see Fig. 5). The whole apparatus is then evacuated by a Gaede vacuum pump which is kept rotating for the whole of the rest of the operation.

The potassium is melted and then runs down into the bulb B1 through the three inverted funnels F1, F2, F3. The tube T is then sealed off from the rest of the apparatus at 2. The cleaned potassium is now distilled successively into bulbs B2, B3, which are then sealed off at 3 and 4 as before. The potassium is now melted.

The joint at J is turned until the

next be treated to render the surface absorbent. Pure hydrogen is now introduced into the cell at a pressure of 0.5 to 1.0 mm. of mercury through the palladium tube P. A discharge from a small induction coil (1/2-inch spark) is then sent through the cell until the potassium becomes a deep violet in colour. After this the hydrogen is pumped out and pure helium is introduced until a pressure of about 0.75 mm. is reached. Sealing off at 6 completes the process.*

This type of cell differs very much

* Full details of the method of filling these cells and their practical use in astronomy are given in "Monthly Notices of The Royal Astronomical Society," March, 1919.

† The energy of the emitted electrons is given by the formula: $eV = h(\nu - \nu_0)$.
 e = electron charge, 4.774×10^{-10} E.S. units.
 V = potential or ionising voltage in E.S. units.
 h = Planck's constant, 6.558×10^{-27} erg/sec.
 ν = frequency of exciting light.
 ν_0 = a definite threshold frequency characteristic of the metal used in the cell.

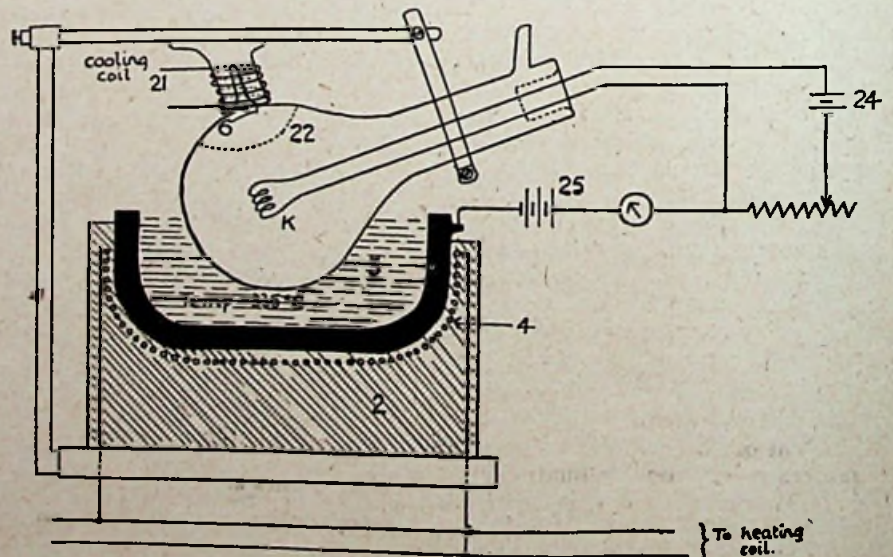

Fig. 6.—Process of manufacture of Zworykin Cell.

At this point it may be of interest to illustrate a method* suggested by Zworykin (Fig. 6) of the Westinghouse Electric Company of America. Photo-

GEC. "Gauze-type" PE CELL

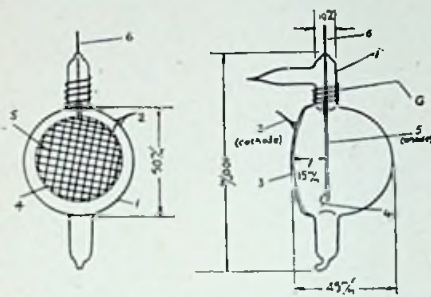

Fig. 7. Illustrating the gauze type of Photo-Electric Cell.

electric cells are provided with a light-sensitive metal by immersing the glass envelope of the cell, freed from oxygen, and containing a heated cathode (K) in a fused salt (3) maintained at a positive electrical potential relative to the cathode (K). Metal ions from the salt (3) replace corresponding metal ions in the glass, these latter ions being liberated as the metal in the container cell.

The Gauze Type.

Considerable progress has been made during the last two years with the gauze type gas-filled cell now being sold for experimental purposes by the General Electric Company.

These cells were introduced by Otto Pressler, of Leipsic. The anode consists of a ring (4) carrying an open gauze (5); (3) is the silvered cathode on which is deposited potassium, sensitised by the usual method, on the nearly plane wall forming the back of the cell. The overall dimensions are slightly in excess of those given for the Lindemann cell.

A rather more technical description of the current-voltage curves of photoelectric cells now becomes advisable. In any gas-filled cell it is always found that the current increases with the illumination, and also with the voltage applied between the electrodes. If the illumination is constant, and the voltage is increased, a stage is always reached eventually at which the current is almost independent of the illumination and does not cease with the illumination.

If the illumination is relatively

* The method is the subject of a British Patent No. 271116.

small, the attainment of this stage is indicated by a comparatively large and sudden increase in current and the appearance of a visible glow discharge. If, on the other hand, the illumination is relatively large, there is no marked discontinuous change in the current.

We therefore have three distinct stages:—

(1) A light-controlled discharge stage.

(2) A transition stage between where the discharge is controlled by the light, and the stage where the discharge is almost independent of the light.

(3) The last, where the discharge passes into the glow-discharge independent of the light.

In the next illustration (Fig. 8), we have a current-voltage curve where the logarithm of the current is plotted against the potential difference applied between anode and cathode. The different curves refer to different amounts of light entering the cell.

It will be noticed that all the curves are of the same general form; they are nearly straight at the lower voltage, rising rather steeply and terminating at a definite point,

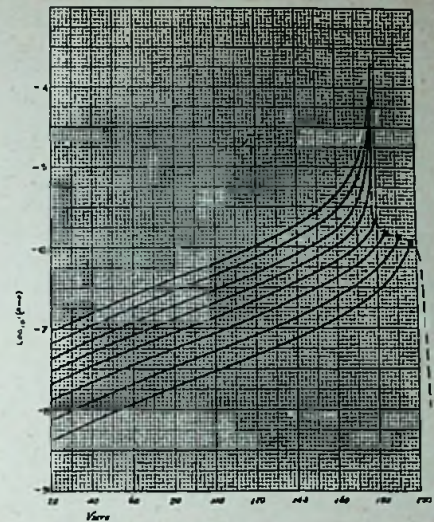

Fig. 8. Current-voltage curves of gas-filled Photo-Electric Cell.

marked X. This is the point where a discharge passes through the cell, accompanied by a purple glow. This glow is almost independent of the light; the current does not cease when the light is turned off.

The thick curve in the diagram is a definite characteristic of the cell, and will be called the "Limiting curve." It divides the diagram into two parts. The region on the left is one where each point represents a definite discharge which can be obtained at some definite voltage, and at some definite illumination, which stops where the light is turned off.

Characteristic Curves.

To the right of the curve is the region where results are either unstable or do not stop when the illumination on the cell ceases. If, therefore, we wish to obtain the maximum sensitivity, it follows that the voltage to be applied to the cell is that just below the point X. It may only be a matter of one-tenth of a volt and the potential is most conveniently dropped by means of a potentiometer, but this can only be done in practice if the source of potential is very steady in action.

So far we have only been considering the question of measuring exactly the amount of light falling on the cell. Our problem in television is not so much to measure the amount of light in absolute units, but to get a very definite and workable response for changes from light to dark.

The following method of using the cell has been devised by Dr. Campbell,

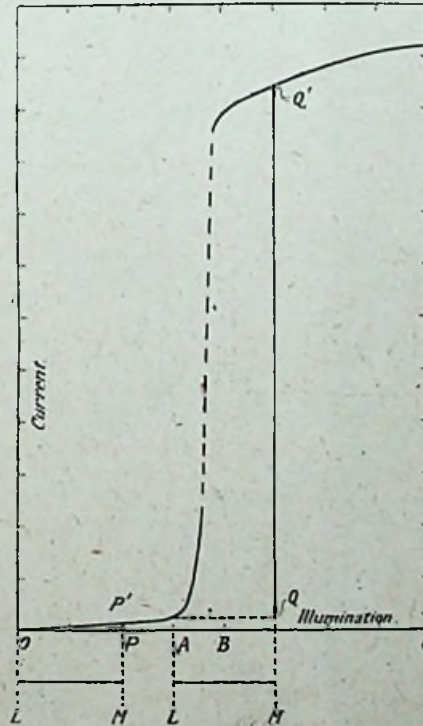

Fig. 9.

Dr. Campbell's method of using a "priming" illumination. The cell response for an illumination equal to LM applied to the cell without priming is PP'. By first priming with illumination equal to QA, the change in cell response current is QQ'.

of the G.E.C. Research Laboratory, to give this effect.†

In the next illustration (Fig. 9) the voltage has been adjusted for maximum illumination. The three ranges of illumination to which we have already referred now appear as: (1) a range OA, in which the current is roughly proportional to the illumination; (2) a narrow range AB in which the current increases so rapidly with the illumination that this is difficult to trace; and (3) a range BC in which the current varies much more slowly with the illumination.

It is required to obtain from the cell a maximum response for a quantity of illumination corresponding to LM.

By applying to the cell a suitable priming illumination OA, the change in current or an increase LM in illumination will be QQ', a very much greater increase than PP', which is the response for an amount LM of illumination falling on the unilluminated cell.

The Zworykin Tube.

Perhaps for general ease of working a combination of cell and valve, designed by Zworykin, and illustrated in Fig. 10, will probably be found the most convenient in practice. This consists of an ordinary three-electrode valve with a photo-electric cell, both mounted within the same

glass bulb, the filament of the valve being of the oxide coated dull-emitter variety, operated at a temperature so low that there is no visible glow. The lower half of the bulb contains the valve proper with filament, grid, and plate, the upper half enclosing the cell.

The second portion of the demonstration was then given, using a photo-electric cell in the same manner as the selenium cell was employed during the first demonstration. The glow discharge point was first reached, the glow being plainly visible. The light source was then cut off and the current passing through the cell was indicated on a milliammeter. Dropping the applied voltage by a few volts, by means of a potentiometer, caused the glow to stop, and the cell was then put into use. Its response to the same tests as applied to the selenium cell was markedly less.

In each portion of the demonstration the same amplifier, light source, and interruptor disc was used, the only change being the different form of light-sensitive device.

The diagram of the circuit used in these demonstrations is given in Fig. 11.

The chairman, thanking Mr. Mitchell for his lecture, said he was sure the audience would agree with him that Mr. Mitchell had dealt with a fascinating subject in a very fascinating way. It was not an easy thing to talk about light-sensitive cells and photo-electric cells, more particularly to deal with their sensitivity and practical application. He

thought they had learned sufficient to stimulate them to continue their experimental work in their own spheres, which was, after all, what fundamentally mattered to a society such as theirs.

The amateur had opportunities for experiment and test which were denied those whose work was in



Fig. 10. Zworykin and his combination photo-electric cell and thermionic valve.

laboratories, and it was a significant fact that the light-sensitive properties of selenium were discovered by accident.

Covering the Entire Spectrum.

As Mr. Mitchell has pointed out, light-sensitive devices varied in their response to light of different wavelengths. Some cells were definitely insensitive to ultra-violet light, others were sensitive to it, and others again were sensitive to infra-red. This variation in response to light of different wave-lengths encouraged the hope that it might be possible, by co-ordinating such cells, to cover the whole of the spectrum and so reach colour television.

That was a possibility of the future, but at present one could not say whether it was near or far. Still, with the knowledge which we already had of the sensitivity of different substances to different parts of the spectrum, it might quite conceivably be possible so to harmonise them in cells in order to project a colour scheme.

† "The Use of Gas-filled Photo-Electric Cells," N. R. Campbell, Phil. Mag., Vol. iii., May, 1927.

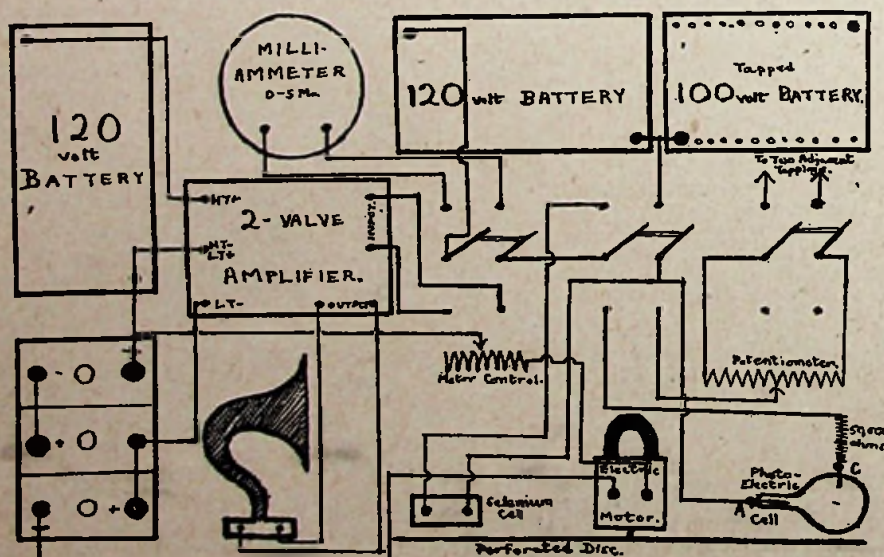

Fig. 11.—Diagram of connections used by Mr. Mitchell for demonstration purposes.

As to which substances were more sensitive than others, and which would give a definite electrical response, that formed a field in which the amateur could do useful work, for our knowledge was as yet far from complete or even very extensive in that direction.

He had already indicated the promise that such work held out for the future, and he hoped that the earnest amateur would take a leading part in advancing that knowledge and retain for us the lead in television work which we already held.

Mr. Mitchell, he understood, was prepared to answer questions arising out of his lecture, or show any part of the apparatus used.

Answering questions, Mr. Mitchell, to show the simplicity of his circuit and apparatus, said the whole of it had been brought 50 miles by motor-car, during the afternoon, and much of it had been wired up on the journey by his assistants.

Dr. Tierney, in closing the meeting and conveying a hearty vote of thanks to Mr. Mitchell, announced that the next meeting of the Society would be held in September. He hoped that in the meantime amateurs would get together. Already, he believed, there were some who were prepared to repeat and extend Mr. Mitchell's experiments and broadcast them, so that they might get experience in picking up and using the type of signals used in television.

Suggestions Wanted.

The secretary of the society would be glad to receive from anyone suggestions for lectures and demonstrations to take place during the winter session.

One suggestion put forward was that they should have "members' nights," when members could demonstrate apparatus that they had tried out and, in an informal way, discuss the results obtained. The suggestion seemed a sound one, and the secretary would arrange for such nights.

Anyone else who had suggestions to make was invited to write to the secretary so that when the winter session opened in September a comprehensive and satisfactory winter programme may be announced.

Due notice of the exact date of the September meeting will be given later in these pages, and in a circular to members.

An Office Boy's Part in Television Experiments

IN connection with his efforts to progress from the transmission of outlines to the sending of true images complete with detail, Mr. Baird is fond of telling the following story:

For the purposes of his experiments he was in the habit of placing before the transmitter the head of a ventriloquist's doll, and his efforts were concentrated in the direction of getting not merely the outline, but a complete detailed image of this doll through to his receiving screen. One day in October, 1925, after months



of patient effort, he had the satisfaction of seeing the doll's face on his receiving screen not as an outline, but as a real image with shading and detail.

Full of enthusiasm and excitement, Mr. Baird rushed out of the laboratory in search of a human "subject" to take the place of the doll. The first human being he met happened to be Mr. William Taynton, who was at that time office boy in the office below. After some difficulty Mr. Baird persuaded Mr. Taynton to come up to the laboratory and take his place before the televisor.

After seating him in the correct position, Mr. Baird dashed through the laboratory to look at the receiving screen. To his great disappointment, however, there was nothing to be seen. After vainly trying various

adjustments he went back to the transmitter to find that the failure of the experiment was due to the fact that his human subject, afraid of the terrific glare of the lights used to illuminate his face, had moved back out of focus.

In the excitement of the moment Mr. Baird offered him half-a-crown to take up his position again and maintain it. This time the image of the boy's face came through clearly on the receiving screen.

As a matter of historical interest it is somewhat strange to have to record that the first human being ever to be televised had to be bribed to accept the distinction!

We have extracted the following from the editorial page of our esteemed contemporary, the *Irish Radio News*, for June 23rd:—

Interest again Stimulated in Television.

There was a possibility that public interest in Television would subside owing to the "cold water" efforts of some people who did not agree with the methods at present being used by some leading experimenters to achieve pure television. It may be that the "cold water" people are right—up to a point, but my own knowledge of public taste is that even if a rough image is given to the public for a start they will be satisfied. A practical demonstration—even if crude—will be something worth while so far as the man-in-the-street is concerned. The theoretical wranglings as to what is right and what is wrong must always needs occupy the attention of scientists and those competent to form reasoned opinions. For that reason I think that the sooner the public is in possession of television apparatus—no matter how crude it may be—the sooner big developments can be expected.

It must be remembered that wireless reception was not perfect three years ago, yet its wonder gripped people. The wonder of television, be it ever so elementary, will grip people even more so. Public interest in the next move of those most intimately concerned with the practical side of the question is proof, if such were needed, that television will receive a tremendous ovation when once it makes its bow to the world.

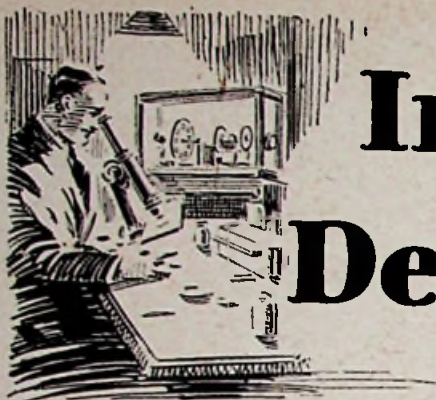

Invention and Development

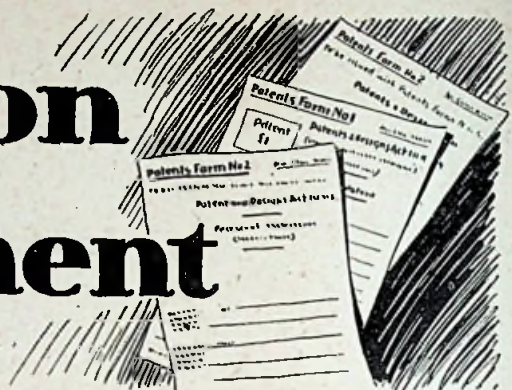

No. 288539—*Electrical Research Products*.—This patent describes the process of manufacture of large photoelectric cells of "test-tube" shape, having the unusually large light-sensitive surface of approximately forty square inches. The cells, an illustration of which appeared in this journal last month, are made of Pyrex heat-resisting glass, their overall dimensions being about one foot in length and several inches in diameter.

The accompanying illustration (Fig. 1) shows the internal tube (11), which carries the helical wound anode (12), adapted so that it can be heated by external means so as to assist the formation of the cathode during manufacture. After the cell has been evacuated the potassium or other alkali metal, contained in the glass bulb (19), is re-distilled successively from bulbs (18) and (16), and deposited on the inner tube (11) and the inner wall of the vessel (10).

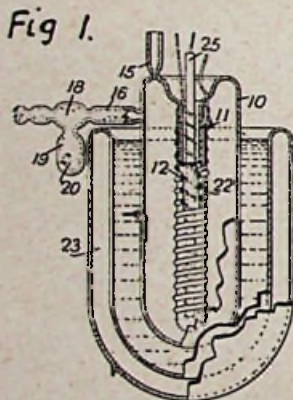

Liquid air is next poured into the tube (11) and the surface of the vessel heated so as to vaporise the potassium from the inner wall and deposit it as a layer (22) on the tube and the anode. The liquid air is then removed from the tube, the vessel is placed in a double-walled receptacle (23) containing liquid air, and a separate heater (25) is inserted in the tube, so as to vaporise the potassium from the tube and anode and produce an even deposit on

the inner wall of the vessel, this inner wall forming the sensitised cathode.

Protection has been granted to B. Rtscheuloff in two recent patents, Nos. 287643 and 288680, for a system of television using vibrating photo-sensitive points. Essentially the apparatus consists of a compound spring made up of two separate springs (a) and (b) (Fig. 3) connected end to end, with their respective planes at right angles to one another, a joint being formed by the ball (A), each spring being caused to vibrate in its own plane (see Fig. 2). The compound spring is mounted within a vacuum tube (C), the end (f) of the spring (b) is fixed; the other free end is coated with photo-sensitive substance. Outside the tube two electro-magnets (M) and (m), fed with alternating current of periodicity 1,000 and 10 cycles/sec., cause each spring to vibrate individually and so the image of (O) formed within the cell by the lens (L) at (O') is scanned completely by this photo-sensitive point (g). The sensitive point (g) is the cathode of the cell; various modifications of anode (N) are indicated in the specification. After amplification at

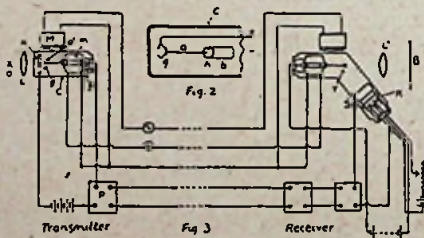

287643 Rtscheuloff's Vibrating-Spring System

(P) the output of the cell is sent either by wire or wireless to the receiver.

A somewhat similar spring vibrating system forms an essential part of the receiver, except that the

point (Y) is here a luminous or fluorescent point, forming the anode of what is virtually a thermionic tube. The received signals are applied to the grid (S) of this tube which serves to control the stream of electrons emitted by the incandescent cathode (K). This bombardment of electrons on the sensitised point as it moves in synchronism with the vibrating spring system at the transmitter reconstitutes the original image, which is then projected by the lens (L') on to a viewing screen (B).

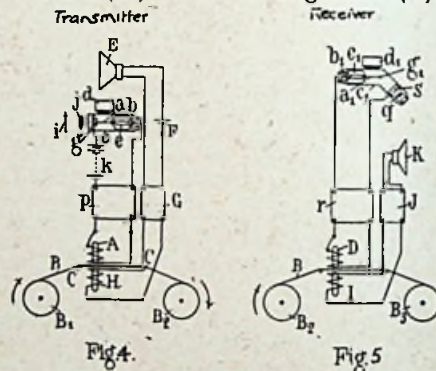

Several modifications of the photoelectric cell arrangement are described in the patent specification.

In Patent No. 288680 (Figs. 4 and 5) provision is made for recording the output of the cell on to a travelling strip (B) of magnetic material or on a disc or cylinder. At the same time a sound record is impressed on the opposite side of the travelling strip or disc by magnets (H) controlled by the microphone (E).

No. 290367, a patent issued to G. M. Wright, embodies a method for overcoming or minimising the time-lag in photo-electric cells, particularly those of the gas-filled potassium and thalofide types. It is pointed out that the lag associated with these cells is of a complex (Continued on page 40).

THE BEST LETTERS OF THE MONTH

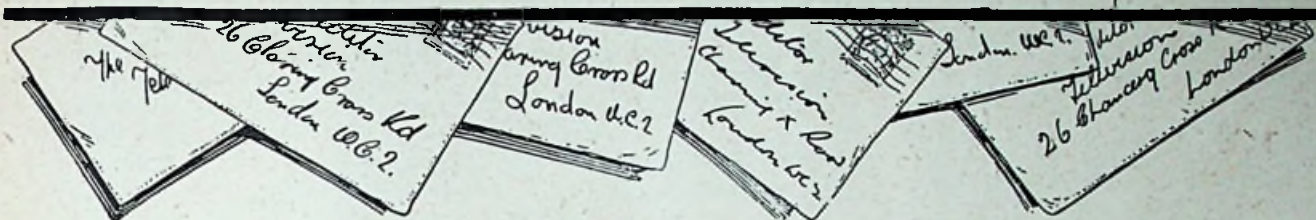

The Editor does not hold himself responsible for the opinions of his correspondents. Correspondence should be addressed to the Editor, TELEVISION, 26, Charing Cross Road, W.C. 2, and must be accompanied by the writer's name and address.

A CORRECTION.

BAIRD TELEVISION DEVELOPMENT
COMPANY, LIMITED,
133, LONG ACRE,
W.C. 2.

June 6th, 1928.

THE EDITOR,

"TELEVISION."

DEAR SIR,

With regard to my lecture as reported in your issue of June, 1928, I should like to make it quite clear that the demonstration of Noctovision referred to under the heading "Invisible Smoke" was not given at the Royal Institution but at Motograph House. A general invitation was issued to members of the Royal Institution, and some forty members witnessed our demonstrations.

Yours faithfully

JOHN L. BAIRD.

[We greatly regret this error, and trust that it has caused no inconvenience.—Ed.]

SUGGESTIONS FOR EXPERIMENTERS.

RIANT-MONT, LA ROSIAZ,
LAUSANNE, SWITZERLAND.

June 1st, 1928.

THE EDITOR,

"TELEVISION."

DEAR SIR,

May I point out a misprint in my letter in your June number; that is the word "nickel" instead of "Nicol," as I fear that some of your readers may be led into confusion. I am afraid I used the word "Nicol" in rather a wide sense of the word as, of course, I meant "Nicol's prism," and must excuse myself for not being precise enough. Of course, any other analyser such as Tourmaline may be used instead of the Nicol's prisms.

There is one other slip to which I would call your attention, and that is the word "changed" instead of "charged"; the last word on the fourth line from the end of the first column. The phrase ought to read, "but which has been charged exteriorly." By charged it is, of course, meant "charged electrically," and here again I must excuse myself for lack of precision: I trust that these mistakes will have caused you or any reader no inconvenience.

My brother's letter in the same issue interested me considerably, and I, too, do agree that a suitable catalyst ought to reduce the lag to a negligible quantity. But I believe that even when the proper catalyst is obtained, the light will have to strike the selenium in certain definite directions to obtain the maximum reduction of the lag. Let me explain: Selenium possesses a definite crystalline structure and is probably more sensitive to light falling on certain of its faces than on others. This can be compared to the piezo-electric properties of certain crystals where pressure in definite directions produces charges (electrical charges) on its extremities, while pressure in another direction may produce no effect whatsoever.

I know the comparison would hold good with no ordinary metal, but selenium is no ordinary metal. If the crystalline structure of selenium is not definitely known it can be determined by the method of Hull, or Debye and Scheerer in X-ray crystal analysis. When once the crystalline structure of metallic selenium is known, and a suitable catalyst is found, its method of formation can be studied in order to obtain a metallic crystal of suitable size so that the light can be concentrated on the face that would give the maximum variations in current intensity for given variations in the light intensity.

Your periodical interests me considerably and I shall never have any hesitation in recommending it to all my friends. The home television for America is certainly very interesting, although I would have liked England to have been the first to have television in the home, and I quite see Mr. Tiltman's point when he says that public opinion is responsible for us not being the first. Yet I believe that when once it takes, and I think it has taken, it will spread quickly, and we shall be as much responsible for improvements as America will.

Yours faithfully,
E. P. ADCOCK.

48, RECTORY ROAD,
LONDON, N. 16.

June 9th, 1928.

THE EDITOR,

"TELEVISION."

SIR,

I have read, with great interest, the

letter you published from Mr. E. P. Adcock, of Switzerland, in the current issue of TELEVISION, and it has caused me to stop, look, and write to you about his suggestion.

Although light waves are electromagnetic they have not yet, as far as I know, been utilised for producing currents in conductors by placing them in the magnetic field. If it does cause effects on conductors, then it is happening everywhere, where there is light and conductors, such as telephone lines, wireless aerials and iron and steel girders.

I do not know if Mr. Adcock is serious, or trying to pull our legs, but I fail to see how his lens and copper-plate arrangement is going to respond to all the lights and darks of the image at the same moment, unless a mechanical means of splitting up the image is used. If the currents vibrate in a large, low resistance conductor such as the copper plate, it would rather circulate round the plate than flow out of it into the neighbouring circuit.

Again, I should like to see a circuit which has a resonance frequency, the same as that of light, since two circuits must oscillate at their own particular frequency before they can be superimposed or heterodyned. As regards the solution other than the present rotating systems, that will come when we are able to evolve an instrument which acts like the human eye. Till then nothing but serious, progressive research will bring us nearer to the solution.

In conclusion, I should be very pleased to know when your correspondent intends to start working on his system, as it will surely be regarded as the most scientific investigation ever carried out.

Wishing the Television Society and its journal the best of success,

Yours faithfully,

SYDNEY GOLDSTEIN.

CITY AND GUILDS
(ENGINEERING) COLLEGE,
EXHIBITION ROAD,
LONDON, S.W.

June 4th, 1928.

THE EDITOR,

"TELEVISION."

SIR,

I read with interest the letter of your correspondent, E. P. Adcock, in the June number. The point which he raises

struck me a short time ago as a possible solution of the television problem, and in consequence I went into the matter further. These investigations lead me to conclude that with present apparatus the scheme is impracticable for the following reason.

Assuming the magnetic field of light produces currents in the copper plate, as indicated in the sketch accompanying his letter, these currents will be at the frequency of the light incident on the plate say, for white light, 541×10^8 kilocycles per second.

Another frequency must now be superimposed on this, such that the difference in frequencies is one which lends itself to treatment by ordinary wireless methods. I have taken this last frequency as 15,000 kilocycles (i.e., 20 metres), and in doing so I realise that this frequency is somewhat low, but it can at any rate be dealt with with certainty by existing wireless methods.

The only method I can think of to obtain a high "oscillator" frequency is by letting a beam of light of known frequency fall upon another copper plate and produce very H.F. currents.

The beat frequency must be of the order of 15 in 500 millions, so that the two light beams must differ in frequency by only 0.00003 of 1 per cent. To keep this percentage difference at a maximum, the light rays must be at the red end of the spectrum, i.e., about 477×10^8 kilocycles frequency.

Taking this particular frequency as the minimum to be used, the other frequency will be $477,000,015 \times 10^8$ kilocycles, and the wavelengths corresponding to these two frequencies are respectively 6289.3102725 and 6289.3184605 Angstrom units [1 Angstrom unit = 10^{-8} centimetres], and the difference between these two is only 0.8188 A.U.

If white light was employed, this difference would be even less, but the practical difficulties of obtaining two beams of light differing in wavelength by even 0.8188 A.U. seem to me to be insurmountable.

I next considered the "double heterodyne" method, i.e., having four light sources acting on copper plates producing currents of frequencies f_1, f_2, f_3 and f_4 . These are combined in pairs, giving two frequencies F_1 and F_2 , such that

$$F_1 = f_1 - f_2 \text{ and } F_2 = f_3 - f_4.$$

These are in turn combined and $F_1 - F_2 = 15,000$ kilocycles.

Values for F_1, f_2 and f_4 were assumed and the others calculated from them so :-

- $F_1 = 1,000,000,000$ k.c.
- $f_2 = 477 \times 10^8$ k.c. (red)
- $f_3 = 506 \times 10^8$ k.c. (orange)
- $F_2 = 1,000,015,000$ k.c.
- $f_1 = 478,000,015,000$ k.c.
- $f_4 = 507 \times 10^8$ k.c.

The wavelengths $\lambda_1, \lambda_2, \lambda_3$ and λ_4 corresponding to f_1, f_2, f_3 and f_4 were determined and give the following values :-

- $\lambda_1 = 6276.1504066$ A.U.
- $\lambda_2 = 6289.3102725$ A.U.
- $\lambda_3 = 5917.1597633$ A.U.
- $\lambda_4 = 5928.8537549$ A.U.

and for the wavelength differences we have :-

- $\lambda_3 - \lambda_1 = 13.1598659$ A.U.
- $\lambda_4 - \lambda_2 = 11.6939916$ A.U.

Thus by employing the double beat

method the wavelength difference between initial beams has been increased by over 1,000 times.

It is possible that this distinction in wavelength might be obtained in practice and I wonder if any of your readers could enlighten me on this point. If not, the process might be extended to eight initial beams, one of which was from the variable image, but assuming the possibility of this, the apparatus would be very large and cumbersome.

Yours faithfully,
"ANGSTRÖM."

AN APPRECIATION.

MOORFIELD, LENZIL,
GLASGOW.

May 30th, 1928.

THE EDITOR,
"TELEVISION."

SIR,
I have learned a great deal from the article in your copy for June by Prof. Fleming about the atom, etc. I have been wondering for about two years as to the hydrogen molecule structure and here it is straight away, also lots more of revelations. He is most lucid. I have got my sixpennyworth this month, anyway!

Yours faithfully,
THOS. H. WEBSTER,
A.M.I.C.E.

SOMERBY HOUSE,
MELTON MOWBRAY,
LEICESTER.

June 4th, 1928.

THE EDITOR,
"TELEVISION."

SIR,
Now that we have seen four numbers, I think it is high time I said "thanks" to TELEVISION. This is the magazine I have been looking for, and although I am very interested in wireless, I have never looked for any wireless journal as I have for TELEVISION. I am simply crazy on this new wonder of Science, and needless to say I received a Constructor's Sub-Licence many weeks ago and am now revelling in the pastime of televisor building.

I was delighted when I found that the Television Society had extended the age of associates to 16 years and over, and I received a notice this morning from the society stating that I have been elected a member by the council. I am, I suppose, one of its youngest members, as I am not yet 17.

Let me again thank you for TELEVISION and I am looking forward to the time when we shall have a weekly journal, or, alternatively, a larger monthly number.

Wishing every success to TELEVISION and the Television Society,

Yours faithfully,
F. W. COLES, B.C.D.

From Louisville, Ky., U.S.A., we have received a copy of the "Portland Civic News," which, in discussing television, makes the following suggestion :-

"We wonder what new term will be adopted to take the place of 'tuning in' as now applied to radio. We respectfully suggest that to 'sight in' would about convey the meaning as applied to television."

(Concluded from page 38.)

character, believed to be due partly to the time necessary for ionisation between the cell electrodes to build up and partly to the fact that the resistance is, in effect, shunted by a small capacity constituted by the cell and the associated connections, which capacity must be charged up before the steady potential can be attained. In this invention there is included in series with the cell an impedance having impedance characteristics substantially similar to those of the cell. In Fig. 6 the impedance network of (roughly) 0.2 henries inductance and 3,000 ohms resistance is shown by (3), the output voltage being tapped off at (5).

Fig. 6

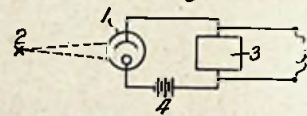
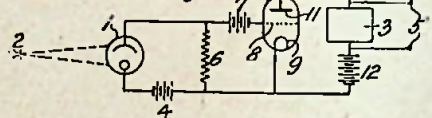

Fig. 7



In the circuit diagram of Fig. 7 a thermionic amplifier is shown with the resistance (6) connected between the grid and filament; (7) is the grid biasing battery. As before, the amplified output voltage is tapped off at (5), the impedance (3) being effectively in series with the light-sensitive cell. In each case it is essential that the impedance chosen should match the impedance of the particular cell being used over the whole range of working frequencies.

The operation of the invention is apparent from a consideration of a balanced Wheatstone bridge having two adjacent arms formed of resistances and two of reactive impedances. Suppose potential to be suddenly applied between those conjugate points of the bridge which lie each between an impedance and a resistance, then there will be no potential difference between the other conjugate points notwithstanding the time-lag of current growth in those arms of the bridge containing impedances. It follows, therefore, that if a varying e.m.f. be applied across two like impedances connected in series the e.m.f. across any one of them will faithfully follow the variations in the applied e.m.f.

W. G. W. M.



MR. BAIRD uses DUBILIER CONDENSERS

THAT Mr. Baird uses Dubilier Condensers in his Television experiments is sufficient to say of their high standard of constant efficiency.

Like Mr. Baird, you appreciate the importance of using only reliable components when building a set, and especially in experimental work; for unless the parts are dependable the results cannot be constantly good.

Build always with Dubilier Components for not only are they good to start with, but their efficiency is steadfast. Type B775 Condensers are made in 14 different Standard capacities between 0.02 and 0.3 at prices ranging from 5s. 6d. to 22s. 6d. If unobtainable from your dealer send direct to us mentioning his name and address.

*Dubilier Built
is Better Built*

©150



Advt. of Dubilier Condenser Co. (1925). Ltd., Ducon Works, Victoria Road, North Acton, London, W.3.

All Communications
respecting

ADVERTISEMENTS

should be addressed to:—

“TELEVISION”

Advertisement Dept.,
Kingsway Corner Buildings,
109, Kingsway, W.C.2.

Telephone: HOLBORN 7070

PRECISION CONDENSERS
for simple tuning

JACKSON BROS
8, POLAND ST. - OXFORD ST.
LONDON - W.1 Telephone: CERRARD 3414

Mention of "Television" when replying to advertisements will ensure prompt attention.

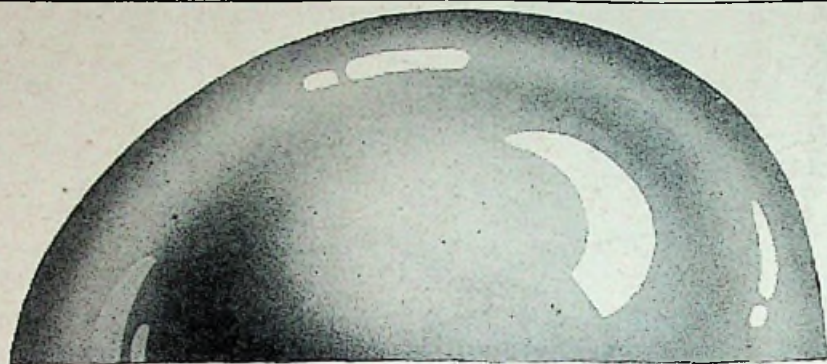

Mullard

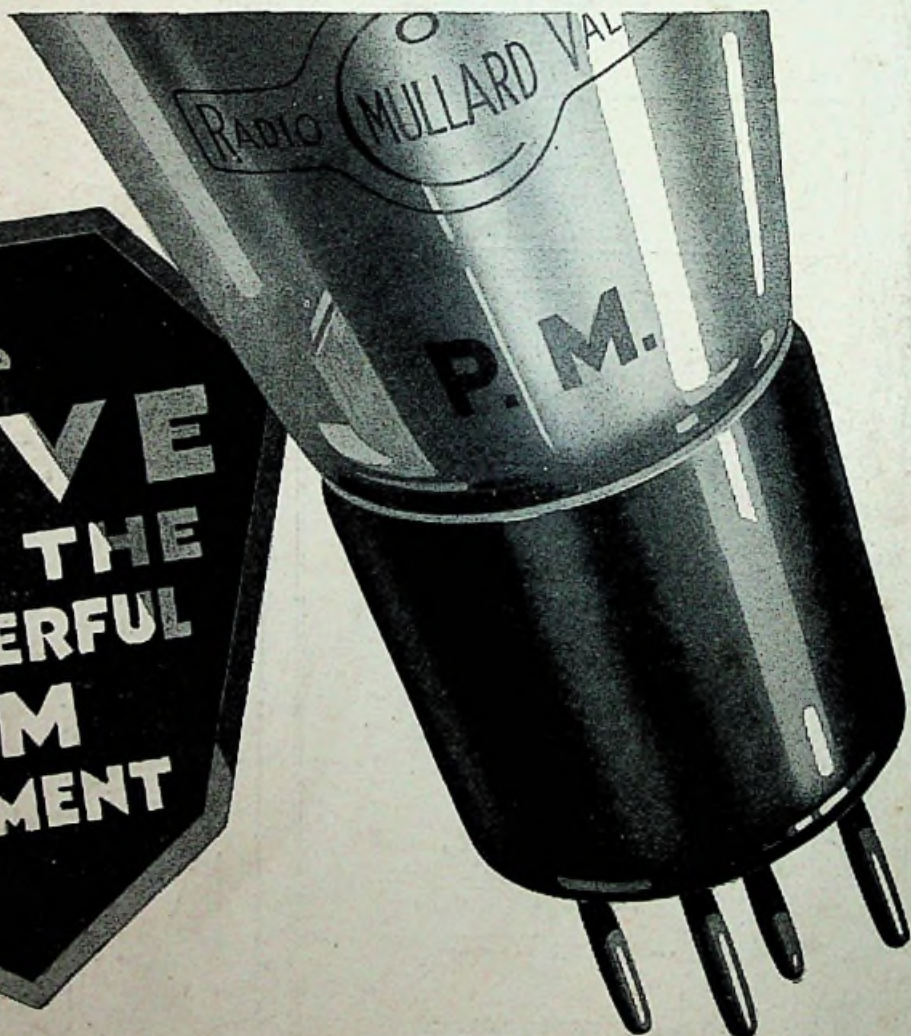

THE · MASTER · VALVE